

S. Whitaker,
Slaw Case.

No. 113,827,

Patented Apr. 18. 1871.

Fig. 1.

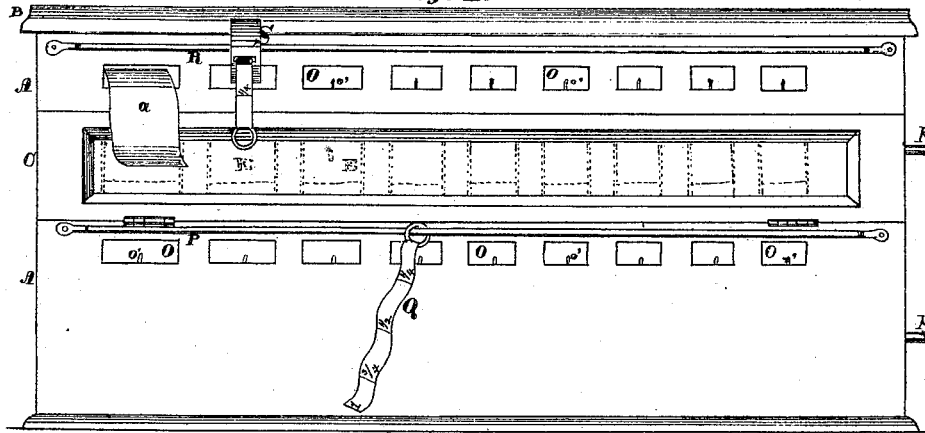

Fig. 2.

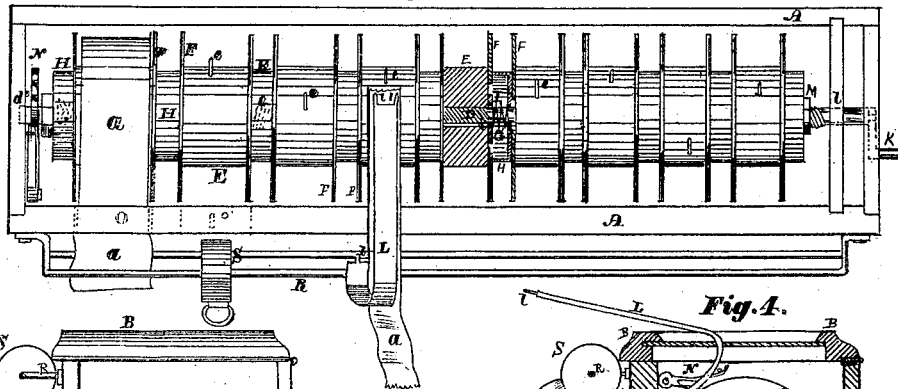
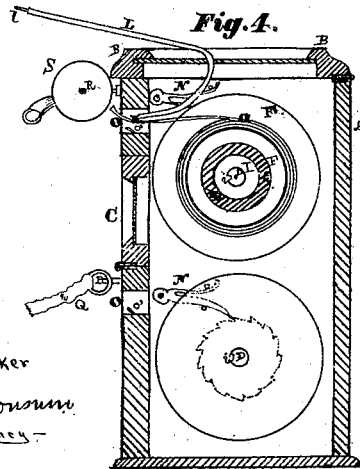
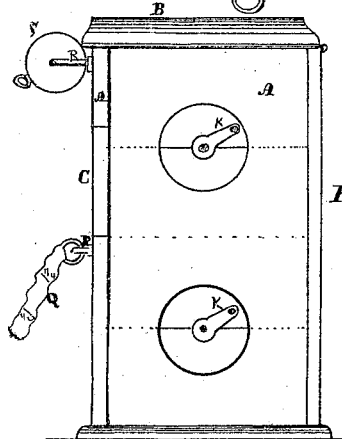

Fig. 3.



Inventor,
 Samuel Whitaker
 by
 Charles P. Mousum
 his attorney

Witnesses:
 William Galley
 James Beniswell

UNITED STATES PATENT OFFICE.

SAMUEL WHITAKER, OF MACON, ASSIGNOR TO HIMSELF AND AARON RUTH,
OF DECATUR, ILLINOIS.

IMPROVEMENT IN CASES FOR RIBBONS, LACES, &c.

Specification forming part of Letters Patent No. **113,827**, dated April 18, 1871.

I, SAMUEL WHITAKER, of Macon, in the county of Macon and State of Illinois, have invented certain Improvements in Cases for Ribbons, Laces, &c., of which the following is a specification:

Nature and Objects of the Invention.

My invention relates to a case for ribbons, laces, &c., so arranged and operated that each spool may be filled separately, and that the protruding end of any coil of ribbon may be drawn so as to obtain any desired length without disturbing the other coils. Measuring-tapes are also attached to the case.

Description of the Accompanying Drawing.

Figure 1 is a side elevation of a case embodying my invention. Fig. 2 is a plan of the same. Fig. 3 is an end elevation. Fig. 4 is a sectional view of Fig. 1.

General Description.

A is the case, made of wood or other suitable material. B is a lid on top, and C a sash on the side of the case, by which access is had to the interior of the case. The lid and sash are provided with a glass.

a a is the ribbon or lace. D is a shaft running the full length of the case, having bearings at *d* and *d'*. Upon this shaft are the spools E E, and on the spool a point, *e*.

F F are flanges to the spools. G is a spiral spring covered by the cap H. Between the spring and spool is a washer, I. K is a crank by which motion is communicated to the shaft.

The machine is operated as follows, viz: The end of the ribbon or lace is fastened to the feeder L, there being sharp points *l l* upon it, by which the ribbon is held. The ribbon is then passed between the flanges F F and fastened to the point *e*, and coiled upon the spools by turning the crank, there being sufficient pressure from the spiral springs to hold the spools.

The washers and cap revolve with the shaft, as there are projections *i i* upon them which fit into a groove in the shaft.

When the spools work loose upon the shaft they can be tightened by the nut M.

After the ribbon is all coiled upon the spool, the end is fastened to the crooked end of the

feeder, as is shown in Fig. 4, there being a point, *l*, to catch the ribbon, and the ribbon passed through the rectangular opening O in the side of the case, the end of the ribbon catching on the point *o'*, preventing the ribbon from going back in the case when the shaft is turned.

When desired, the ribbon is removed from the case by pulling on the end of the ribbon, the spool revolving on the shaft, the other spools remaining stationary.

The ratchet-wheel and pawl N prevent the shaft from a reverse motion.

When the ribbon is fastened to the point *o'* it will prevent the spool from revolving when the shaft is turned, so that each of the spools may be considered as having an independent motion of all of the others when the ribbon is fastened, as stated above.

Any number of spools can be put upon the shaft, and the case made with two or more sets of spools.

P is a rod, upon which slides a ring, to which is attached a measuring-tape, Q. R is a rod, upon which is fastened a spring tape-measure, S, so arranged that the box in which is the tape-measure and spring will slide from one end of the box to the other.

These tape-measures are for the purpose of measuring the ribbon, lace, &c., as it is removed from the box. Either measure can be used.

Claims.

I claim as my invention—

1. The shaft D, crank K, spool E, flanges F F, washer I, spiral spring G, cap H, nut M, and ratchet-wheel and pawl N, arranged and operating substantially as described, and for the purpose herein set forth.
2. The spool E, point *e*, opening O, point *o'*, feeder L, and points *l l*, substantially as and for the purposes described.
3. The rods P R, measuring-tape Q, and spring tape-measure S, when arranged and used for the purpose hereinbefore set forth.

SAMUEL WHITAKER.

Witnesses:

MONROE SUTTON,
ALBERT T. RISLEY.