

CONTENTS

LENO WEAVES		<i>Pages</i>
Plain Gauze		1-33
Introduction		1- 2
Plain Gauze on Closed-Shed Looms		3-25
Bottom Doups		3-19
Harnesses; The slackener; Arrangement of harnesses and ends; Operation of harnesses; Methods of representing the weave, and harness and chain drafts; The weave; Harness, and chain draft.		
Top Doups		19-25
Construction and arrangement of harnesses; Operation of harnesses.		
Plain Gauze on Open-Shed Looms		26-31
Additional mechanisms required; The jumper; The yoke.		
General Considerations		32-33
Fancy Gauze, or Leno		34-65
Methods of Producing Fancy Gauze Effects		34-63
Combination of Right-Hand and Left-Hand Doups....		34-35
Effects Formed by Inserting Two or More Picks Before Douping		36-37
Weaves in Which the Doup and Ground Ends Work Plain		38
Weaves Produced by Two or More Doup Ends or Two or More Ground Ends		39-45
Effects Requiring More Than One Set of Doup Ends..		46-51
Combination Leno Effects		52-57
Effects Obtained Without the Use of Additional Mechanisms		58-61
Effects Produced Independently of the Weave		62-63
Dissecting Leno Weaves		64-65

LENO WEAVES

PLAIN GAUZE

INTRODUCTION

1. **Leno weaves** is the general term applied to all classes of weaves of a peculiar structure in which some of the warp ends do not lie parallel with, but are twisted partly around, other ends. This principle of interweaving is called **leno weaving**, or **cross-weaving**, and admits of a great number of variations and combinations in developing ornamental effects decidedly different from those produced by the ordinary method of fancy weaving. As every leno weave is what is termed the *plain gauze* weave, or some variation or enlargement of it, or a combination of an ordinary weave with it, known as *fancy gauze*, the subject of leno weaves is best treated in its natural divisions—plain gauze and fancy gauze.

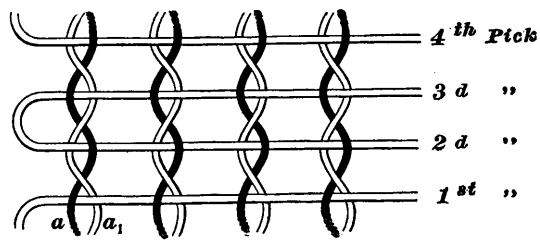

FIG 1

2. A **plain, or pure, gauze fabric**, as represented in Fig. 1, is one in which an end of the warp is raised on one side of an adjacent end on one pick and raised on the other

side of the same end on the next pick. Thus in Fig. 1, the end a , which is known as the **doup end**, is raised over the first pick on the left of the end a_1 , which is called the **ground end**; but on the second pick, a is raised on the right of a_1 . It will also be noted that the doup end a is raised and the ground end a_1 depressed on every pick, the formation of the cloth being made possible by the doup end crossing the ground end between the picks. The weave is complete on 2 picks, as the succeeding picks are merely repetitions of the picks described. Two ends only are required for the completion of this weave, since the entire warp is composed of pairs of ends, each pair working similarly to the 2 ends described. Thus throughout the width of the warp the doup ends are raised over every pick inserted, first on one side and then on the other side of the ground ends around which they twist. Between the picks, each doup end crosses under the ground end with which it works.

This method of interlacing results in several features peculiar to leno weaves. Since the ends of the warp cross each other and more room is usually allowed them than if they were parallel in the cloth, an openwork effect is produced. This open effect is often increased by leaving more space between the pairs of ends than is actually required for their proper working; this is done by leaving certain dents of the reed empty. Since the crossing of the ends prevents the beating up of the filling as close as in ordinary cloths, the openness of leno fabrics is still further increased.

The crossing of the warp yarn binds the warp and filling very firmly together, so that the plain gauze weave makes the strongest cloth that can be woven with a given weight of yarn. A gauze fabric may thus have an open, or lace-like, appearance, be light in weight, and yet possess sufficient strength to wear well.

A peculiar zigzag effect, due to the twisting of the ends, is also characteristic of leno fabrics, but this effect is much more noticeable in fancy gauze than in plain gauze weaves for reasons that will be obvious as these weaves are studied in detail.

PLAIN GAUZE ON CLOSE-SHED LOOMS

BOTTOM DOUPS

3. The majority of gauze fabrics are woven on dobby looms, of either the *close-shed* or *open-shed* type. The terms close-shed dobby and open-shed dobby are practically synonymous with the terms single-lift dobby and double-lift dobby so frequently used in the cotton-mill industry. There is some confusion as to the exact meaning of these latter terms, but the consensus of opinion is that a single-lift dobby is one with but one lifting knife, or bar, while a double-lift dobby is equipped with two knives. Single-lift dobbies form a close shed, while double-lift dobbies, such as are ordinarily used in cotton mills, generally form open sheds. A close-shed dobby is therefore usually understood to be a single-lift dobby, while the term open-shed dobby generally infers a double-lift dobby.

4. **Harnesses.**—The crossing of the ends in weaving plain gauze requires extra harnesses, so that 4 harnesses are necessary, as well as special mechanisms, to control the warp yarn. Two of the harnesses are of the usual type, but in gauze weaving they are called the *ground* and the *back harnesses*. The other harnesses are of peculiar construction and are called the *standard* and the *doup harnesses*.

The **standard harness**, shown in Fig. 2, is like an ordinary harness with the exception that each heddle has two eyes instead of one. Sometimes heddles are used that have eyes

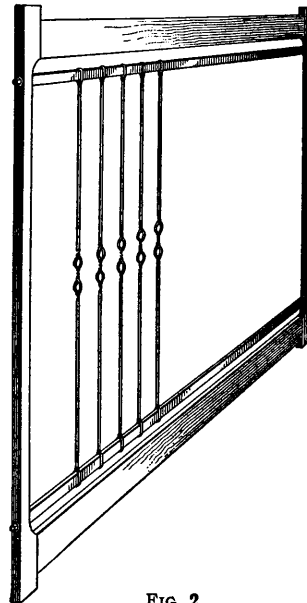

FIG. 2

of the same size, but heddles with the upper eye, in the case of bottom doups, considerably larger than the lower are often used on the standard harness. A standard heddle that has one eye larger than the other will not chafe the doup so much as when both eyes are of small size.

The **doup harness**, shown in Fig. 3, consists of a frame similar to that of an ordinary harness, to the lower part of which are attached worsted, cotton, or linen loops, called **doups**—**bottom doups** in this case, because they are

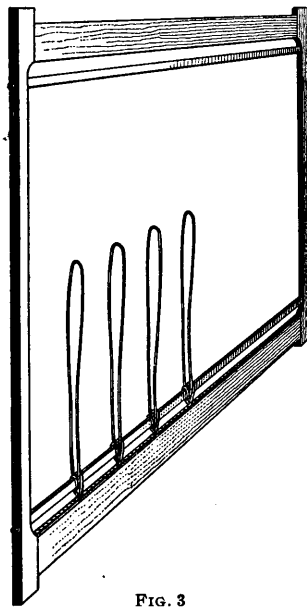

FIG. 3

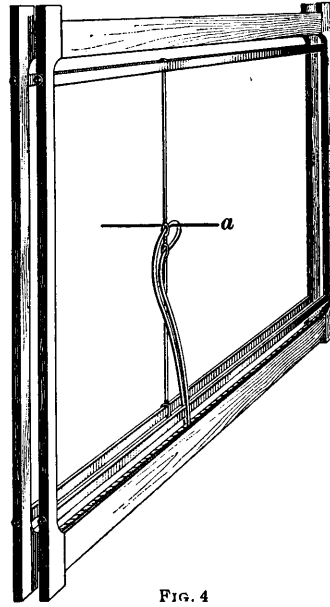

FIG. 4

attached to the lower part of the harness frame. Worsted yarn is preferred for this purpose on account of its elasticity and superior wearing qualities. Heddles are not used on the doup harness. In order to provide for crossing the doup and ground ends in weaving, it is necessary to combine the doup and the standard harnesses in the manner shown in Fig. 4. In attaching the doup harness to the standard harness one end of the doup is fastened to a cord stretched tightly across the lower part of the doup-harness frame;

the other end is passed around the heddle bar, through one eye of the standard heddle, back through the other eye, and, after being passed around the heddle bar again, is fastened to the cord beside the first end. It is not essential that the cord be placed in the exact position shown in Fig. 3. It may be higher up and nearer to the heddle bar, or it may be about $\frac{1}{4}$ inch above the heddle bar; in fact, the latter is the position preferred by many. It is secured on each side either by being passed through holes in the side piece of the harness frame and tied there, or by being attached to hooks fixed on the inside of each side piece of the harness frame. Sometimes the doups are merely fastened to the heddle bar and no cord is used. In Fig. 3, the proper method of passing the doups around the heddle bar of the doup-harness frame is shown; in Fig. 4, and other figures, the doup is simply indicated as being attached to the cord. No ends are drawn through the standard heddle, but the doup end is drawn through the loop formed by the doup passing through the eyes of the standard heddle. If the loop is on the right of the standard heddle, as in Fig. 4, it is a *right-hand doup*; if on the left, it is a *left-hand doup*.

5. The Slackener.—The normal position of the doup end is on one side of the ground end, but on every alternate pick it is crossed under the ground end and raised on the opposite side. Whenever this crossing takes place, an additional strain would be brought on the doup ends if some arrangement were not provided to compensate for the extra length of warp yarn required by the crossing action of the doup ends. To obviate this difficulty a mechanism, called the **slackener**, **easing bar**, or **easer**, is applied to the loom, the object being, as previously intimated, to give a little slack to the doup ends when they are raised out of their normal position. This arrangement is shown in Fig 5; d is a rod extending the width of the loom, attached at one side to an arm d_1 and at the other side to a similar arm. These arms are fastened to a rod d_2 , to the end of which nearest the dobby another arm d_1 is fastened. The arm d_1 is connected

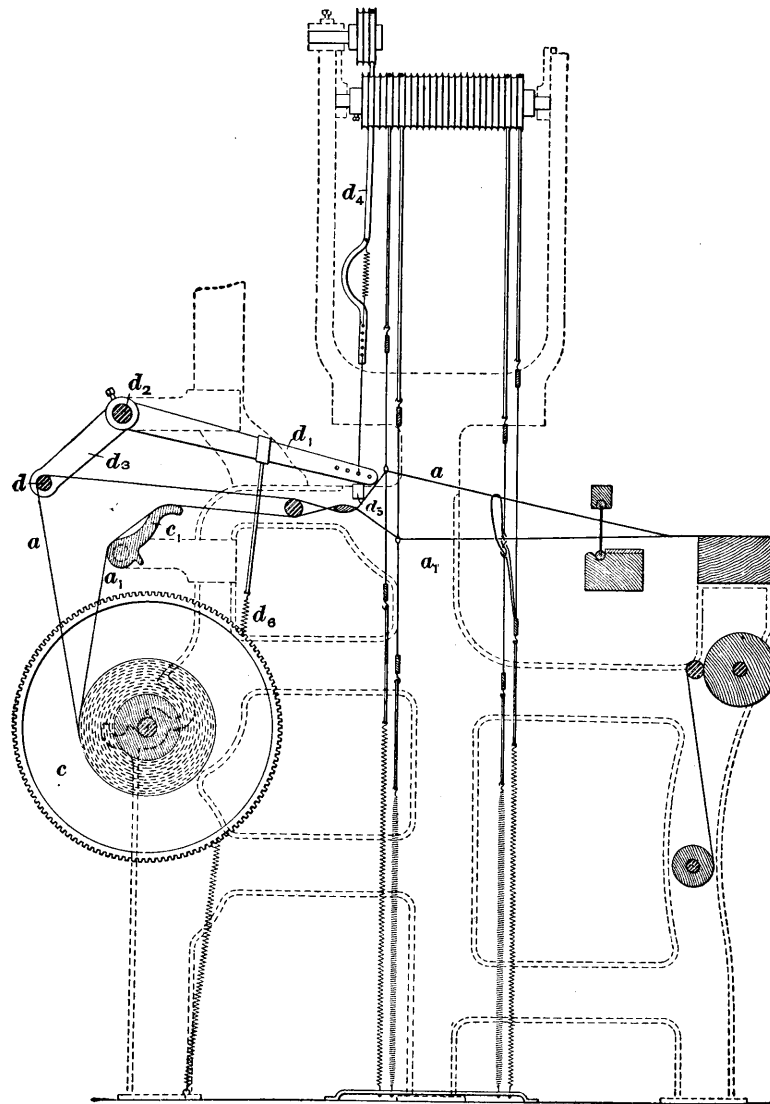

FIG. 5

by a strap d , which passes over a separate sheave attached to the arch of the loom, as shown in Fig. 5, to one of the harness levers of the dobby. This lever is usually the one farthest from the fell of the cloth and is operated in the ordinary manner by the dobby. The warp in weaving a plain gauze is usually wound on one beam c , and the ground ends a , passed over the whip roll c_1 in the ordinary manner. The doup ends a , however, are passed over the bar d of the slackener; thus whenever the doup ends are required to cross the ground ends and be raised out of their normal position, they may be slackened by placing a peg in the harness chain so as to raise the lever that operates the slackener. When this lever is raised, the bar d will be drawn in so as to give the required slack to the doup ends; this is necessary on every alternate pick of a plain gauze weave.

6. Arrangement of Harnesses and Ends.—The crossing of the doup and ground ends in weaving necessitates a peculiar arrangement of the harnesses and the ends controlled by them. The 4 harnesses already mentioned are arranged in the following order, beginning at the front: doup harness, standard harness (through the heddles of which the dous pass), ground harness, and back harness. The ground and the back harnesses are usually placed as far back as possible, so as to put the least possible strain on the doup ends when the crossing takes place. In the European method of weaving lenos, the relative position of the last 2 harnesses is reversed; but they are operated in the same manner as in the American system to obtain like results.

Fig. 6 shows the arrangement of the harnesses and the method of drawing in the doup and ground ends. The doup end a is first drawn over the slackener rod d , Fig. 5, and through the back harness and doup, as shown in Fig. 6. Although this end is usually called the doup end, it is also called the *douping end*, *crossing end*, or *whip end*. The ground end a , is drawn in the usual manner over the whip roll and through the ground harness, but is then crossed over the doup end; it is then drawn in the same dent in the reed as the

doup end. This reeding is absolutely necessary in order to allow the ends to cross in front of the reed. If the ground end and the doup end were not drawn through the same dent of the reed, whenever the doup end crossed the ground end the split of the reed would prevent the crossing from passing forwards; and in consequence, no shed could be formed in front of the reed. This would take place on every alternate pick in the case of plain gauze. It must be understood that

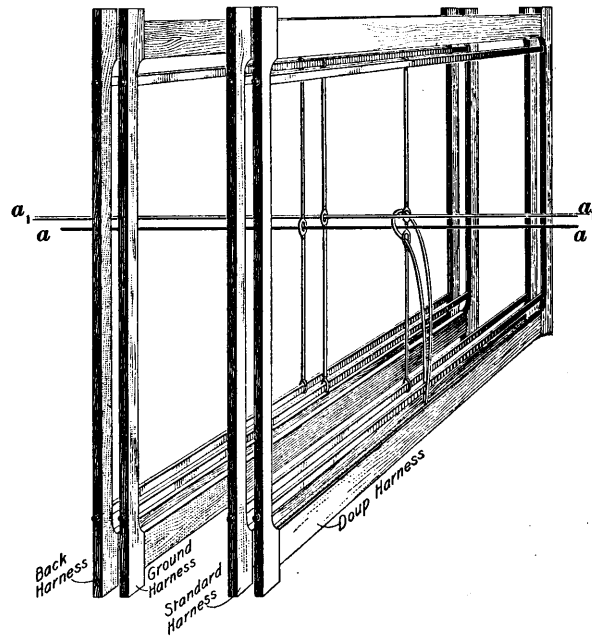

FIG. 6

in plain gauze every alternate end throughout the body of the warp is a doup end drawn in like a , and that the other ends are ground ends drawn in like a_1 , though for convenience of explanation only 2 ends are shown.

7. Operation of Harnesses.—The operation of the harnesses when a plain gauze fabric is being woven on a close-shed loom, will now be considered. It has been noted in Fig. 1 that the doup end a is raised on every pick, but on

successive picks is on opposite sides of the ground end. On the first pick, the doup end is raised on the left of the ground end and passes straight from the back harness to the fell of the cloth, as shown in Fig. 7. On this pick the ground harness remains down, as does also the standard harness; the back harness is raised, in order to lift the doup end, and the doup harness must also be lifted, so that the doup end

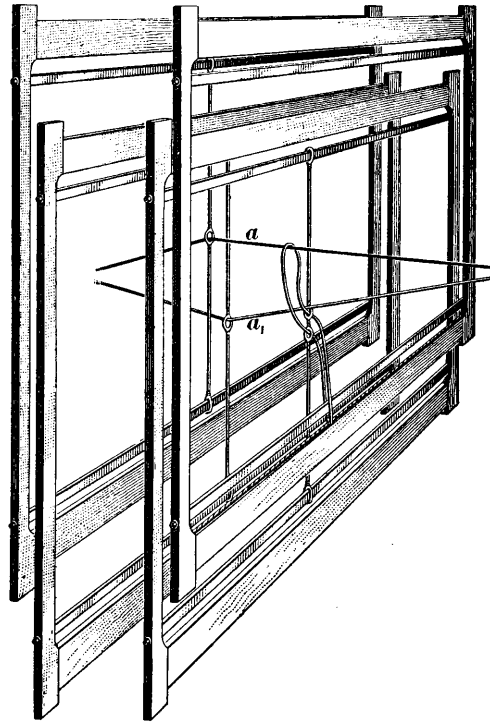

FIG. 7.

in rising may pull the doup through the eyes of the standard heddle. If the doup harness were not raised, the back harness could not raise the doup ends, as the doups would hold them down. After the pick has been inserted in the shed, the harnesses are returned to the bottom of the shed, as shown in Fig. 6. On the second pick the doup end is raised on the right of the ground end, which it crosses in forming

the shed, as shown in Fig. 8. The doup end is raised on this pick by lifting both the doup and standard harnesses, which act as one. As the ground harness is down, the back harness must also be down to avoid straining the doup end, since the doup end crosses the ground end directly in front of the ground harness.

It is evident that when this crossing of the ends takes place and the shed is formed wholly in front of the ground

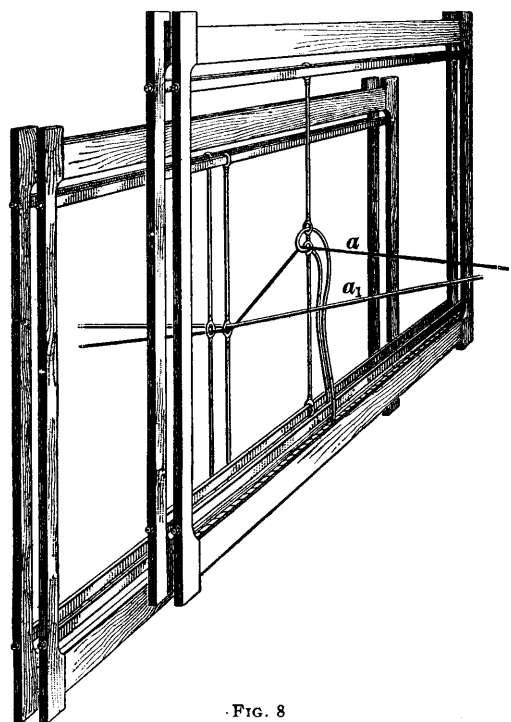

FIG. 8

harness, there is considerable strain on the doup end. The slackener, shown in Fig. 5, is designed to relieve the tension of the doup ends, which are drawn over it, by moving the rod *a* forwards as the crossing takes place. This second pick completes one repeat of the weave, and after it has been inserted the doup and standard harnesses, as well as the lever of the dobbie that operates the slackener,

are lowered and all the harnesses are level at the bottom of the shed, as shown in Fig. 6, ready for another repeat of the weave.

In summarizing the operation of weaving plain gauze on a close-shed dobby, it may be said that the ground harness is never raised and that on one pick the doup and back harnesses are raised, while on the next pick the doup and standard harnesses are raised and the slackener is operated.

8. A careful study of Figs. 6, 7, and 8 will show that the several harnesses and the slackener must be operated as described, in order to form properly the sheds required in weaving plain gauze without putting undue strain on the yarn and the doups. The positions of some of the harnesses might be changed and plain gauze could still be woven, but these changes would be of no particular advantage and would involve several disadvantages. As has already been stated, in the European method the ground ends are drawn through the last harness and the doup end through the next to the last harness. The ends controlled by these harnesses, however, are operated in the manner described, and there is practically no choice between the convenience and effectiveness of the two systems. The doup and standard harnesses could be reversed in position, but there would be no advantage in this arrangement, and broken doups could not as easily be replaced.

9. When the crossing of the doup and ground ends occurs, it is desirable, in order to put the least strain on the ends, to reduce as far as possible the angle formed by the ends in front of the point of their intersection, which is just in front of the heddle eye through which the ground end is drawn. This object is accomplished by placing the ground and back harnesses as far back in the loom as possible, and the doup and standard harnesses at the front. In weaving plain gauze, the available harnesses between the doup and standard harnesses at the front and the ground and back harnesses at the rear are not used at all. When the plain gauze weave is combined with a plain or a fancy weave in

the production of fancy gauze, or leno, fabrics, as explained later, the ends required for the ordinary weave are drawn on the inner harnesses between those that are required at the front and back for weaving the gauze.

10. The doup harness is so constructed that when it is lifted it lifts only the bottom of the doup, while the doup itself must be lifted from the top either by the doup end, when it is raised by the back harness on one side of the ground end, the standard harness being down and the doup sliding loosely through the eyes of the standard heddle, or by the standard harness, when it raises the doup end on the other side of the ground end. If the standard harness is raised, in order to raise the doup end, and the doup harness is not lifted, the entire weight of the doup harness must be sustained by the doups; thus they will be strained or worn out very quickly. On the other hand, if the back harness is raised without raising the doup harness, the doups will hold down the doup ends, thus preventing the formation of a shed and producing considerable strain on the doups and the doup ends. This difficulty, however, is obviated if the doup harness is raised when the back harness is raised, since the only strain on the doups is, in this case, their own weight and a slight amount of friction, which is unavoidable. In view of these facts, it is evident that in weaving plain gauze it is necessary to raise the doup harness on every pick, since the standard harness must be raised on one pick and the back harness on the next pick.

Another important matter connected with the doup and its operation is the relative position of the loop and the standard heddle. In order that the standard and doup harnesses may work properly in weaving plain gauze, it is necessary to have the loop of the doup on the same side of the standard heddle that the ground end is drawn. Thus in Fig. 6, the ground end is drawn at the left of the standard heddle, and the doup end, drawn through the back harness at the left of the ground harness, passes under the ground end through a left-hand doup. If the doup and ground ends were drawn at

the right of the standard heddle, a right-hand doup would be required.

11. Methods of Representing the Weave, and Harness and Chain Drafts.—The study of gauze weaving brings up for the consideration of the designer several points that are not involved in the weaving of ordinary fabrics. Among the most important of these are the representations on paper of the weave and the harness and chain drafts. In a fabric woven in the ordinary manner, each end of the warp is drawn through one harness only and is drawn straight from the beam through the harness to the reed. So far as the weave itself is concerned, the number of harnesses used is the same as the number of ends in the warp that have different interlacings, and the chain draft shows the operation of each harness. In gauze fabrics, the ground ends are drawn through one harness of the ordinary type, while the doup ends are drawn through an ordinary harness at the back, crossed under the ground ends, and also drawn through the doups, which are controlled by both the standard and doup harnesses at the front. Thus in weaving plain gauze, twice as many harnesses are required as there are ends that work differently.

In order to show clearly the method of drawing in the doup and ground ends and their operation, a special system of representing the harness and chain drafts must be used. In making the harness and chain drafts it is necessary to keep in mind which are the doup ends and which are the ground ends. When looking at the surface of a plain gauze fabric that is up in the loom, the doup end is the one that is raised on every pick, but on successive picks is raised on opposite sides of the ground end, which is depressed on every pick.

12. The Weave.—The representation on paper of a gauze weave does not follow the rules that apply to the representation of the weaves of ordinary fabrics. The ordinary method makes use of design paper divided into squares by vertical and horizontal lines. A vertical row of squares is

used to show the interweaving of a warp end and a horizontal row shows a pick of filling. Thus each square represents the intersection of an end and a pick. If the square is marked, it indicates that the end is raised over the pick; if it is blank, it indicates that the end is depressed and the filling floats over it at that point.

This method of representation cannot be applied to the weave in gauze fabrics. The first pick of a plain gauze weave, shown in Fig. 1, may be represented in accord with the principles of this method, since there would be a mark on each alternate end, showing that the first, third, fifth, and seventh ends were raised above the filling and the second, fourth, sixth, and eighth ends depressed, just as in the representation of an ordinary plain weave. The second pick, however, presents several difficulties, since the first end is found to have changed its place and to have assumed a



FIG. 9



FIG. 10

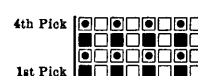

FIG. 11

position that in the plain fabric would have been occupied by the second end, which has also changed position and assumed the place of the first end. If this change in the positions of the ends is ignored and the interlacing of the ends is marked on design paper in the ordinary way, the result will be a series of black marks in one vertical row and blanks in the next vertical row, as shown in Fig. 9. This will show one-half of the warp ends raised and the other half depressed on every pick, in which case there will be no interlacing of warp and filling, and hence no production of a fabric. If the change in the position of the ends is taken into account, but the crossing itself is ignored and the ends are marked according to their position in the cloth, the result will be that shown in Fig. 10; this gives the impression that the fabric is an ordinary plain cloth, which is obviously incorrect.

13. Two methods of representing gauze weaves on paper suggest themselves. The first is to use design paper, but to

adopt different marks to indicate different positions of the ends. Since the ground ends are never raised, the squares showing the working of these ends are left blank. Two marks should be used to indicate the working of the doup ends, one mark, a filled-in square, for instance, for the raising of the end on one side of the ground end in its normal position, and the other mark, a dot, for the raising of the end on the other side of the ground end in its crossed position. According to this method, the weave shown in Fig. 1 would be represented on design paper as shown in Fig. 11. On the first pick, the first, or doup, end is shown raised in its normal position, in this case on the left-hand side of the ground end, and the next end, which is the ground end, is shown depressed, as indicated by the blank; the other pairs of ends are repeats of the first and second ends. On the second pick, the crossing end is raised, but as this is shown by a dot instead of a filled square, it indicates that the doup end is raised on the opposite, or right-hand, side of the ground end after the crossing has been completed. The second, or ground end, is shown depressed by means of a blank, as on the first pick. The other pairs of ends are repetitions of the first and second ends, and the third and fourth picks are repetitions of the first and second picks, since the plain gauze weave is complete on 2 ends and 2 picks.

The system just described is not one that gives at first glance a clear conception of the fabric represented, as it requires a little study before the observer can correctly picture the fabric in his mind. It may be made more clear by the use of color; for instance, by using marks of different colors to represent the raising of the crossing end in different positions; but even these markings are not satisfactory, and this system is therefore not commonly used.

14. The other method of representing a gauze weave on design paper is a diagrammatic one. A typical representation of such weaves that would be entirely satisfactory and could not possibly lead to error or misinterpretation would be to make a sketch or drawing of the ends and picks

composing the fabric, showing their relative positions to one another at every pick and the crossing between the picks; but this would require too much time and practice and some knowledge of freehand drawing. A system, therefore, in common use is a modified system of sketching the cloth, representing it by a diagram. In this case, lines are ruled on a piece of paper, as shown in Fig. 12 (a) dividing it into equal-sized squares. Each vertical line represents a ground end, and each horizontal line, a pick of filling. This differs from the regular use of design paper, where the rows of squares, or the spaces between the lines, represent ends and picks, respectively. In this system some method must be adopted to indicate when an end is up and when it is down. Therefore, at each point representing the intersection of

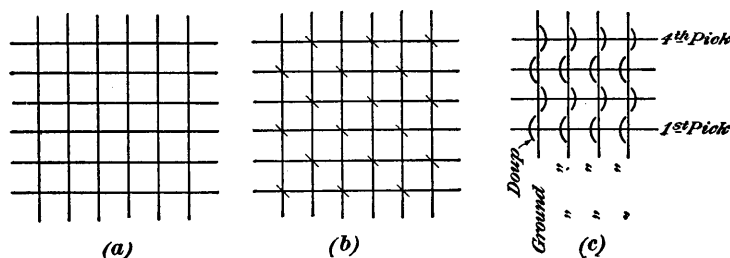

FIG 12

warp and filling, a short, oblique mark is made where the warp is raised over the filling, and no mark where the filling is over the warp. By such a system an ordinary plain weave (not a plain gauze weave) would be shown as in Fig. 12 (b). A plain gauze cloth, as shown in Fig. 1, is shown on paper by this system in Fig. 12 (c). Curved marks, either in black ink or colored ink, are made to indicate the crossing of the doup end and show on which picks it is raised on the right of the ground end and on which picks it is raised at the left of the same end, as will be seen by comparison with Fig. 1.

15. Harness Draft.—The majority of gauze fabrics are woven on dobbie looms, but simple leno weaves may be made on cam-looms, although this is seldom if ever done. Whether cams or dobbies are used, it is necessary to adopt

a system of representing the method by which the ends are drawn through the harnesses, so that when prepared by the designer it may be intelligible to the person who must draw in the ends.

In making a harness draft for a gauze fabric it is necessary to keep in mind the construction and arrangement of the harnesses and the method of drawing in the ends, since these differ radically from the arrangement of harnesses and method of drawing in employed in weaving fabrics of the ordinary construction. It is customary when indicating the drawing-in draft of a gauze, or leno, fabric to make a diagrammatic sketch, ruling horizontal lines to represent the

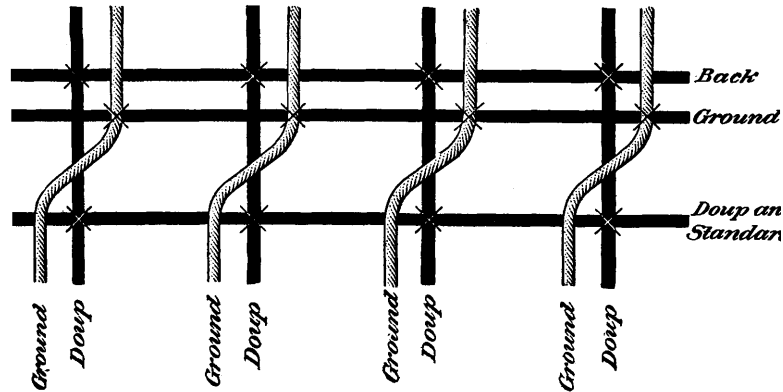

FIG. 13

harnesses, vertical lines to represent the doup ends, and curved lines to represent the ground ends, marking with a small cross where each end is drawn through its respective harness. Such a harness draft is shown in Fig. 13, the horizontal lines, representing the harnesses, being marked with the names *Back*, *Ground*, and *Doup and Standard*; the ends drawn through each harness are indicated as explained, as is also the position of the doup end with relation to the ground end. This draft shows the drawing in of the 8 ends represented in Fig. 1, with the harnesses arranged as in Fig. 6. In Fig. 13, it will be noticed that the doup and standard

harnesses are shown as 1 harness. This is because the doup end passes through the loop that is formed by the doup passing through the eyes of the standard heddle. So far as position is concerned, the doup and standard harnesses may be considered as one when drawing in the ends, but it must be kept in mind that no end is drawn through either eye of the standard heddle.

There are numerous modifications of the draft shown in Fig. 13 in use in different mills, one of them being like Fig. 13 with the exception that the doup and standard harnesses are shown separate. A very common method of representing the harness draft is similar to that shown in

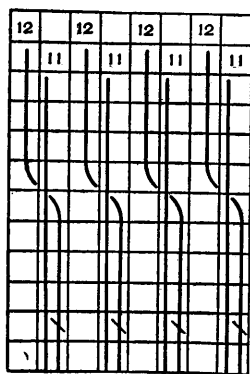

FIG. 14

Fig. 13, with the exception that the doup end is shown by a curved line and the ground end by a straight line. In another system, the draft is marked on design paper, with each horizontal row of squares denoting a harness and each vertical row representing an end, as shown in Fig. 14, which gives a draft of the same ends as those shown in Fig. 13, the doup and the ground ends being drawn through the twelfth and eleventh harnesses, respectively, the doup ends also passing through the doups connected with the second, or standard, harness, as indicated by the short oblique lines. In Fig. 14 it will be noticed that 8 harnesses have been skipped, in order to allow room between the standard and ground harnesses for the crossing of the ends to take place. The manner in which the doup and ground ends that work together are reeded is so well understood by the person who draws in the ends that the reeding is not always indicated. If, however, it is indicated, the ordinary method of enclosing, by marks placed below the harness draft, those ends that are reeded in the same dent is usually employed. If any dents are skipped between the pairs of doup and ground ends, in order to produce a more open effect, they are indicated in the

ordinary manner by the reed draft at the bottom of the harness draft.

16. The **chain draft** for a gauze weave is shown, in the same manner as other chain drafts, by means of design paper on which the vertical rows of squares represent the harnesses, and the horizontal rows, the picks, or bars, of the harness chain. A marked, or filled-in, square shows that the harness represented by the vertical row of squares in which it is placed is raised over the pick represented by the horizontal row of squares in which it is placed. Three columns must be reserved to indicate the working of the 3 harnesses required to manipulate the doup end; also one column for the ground harness; and one column for the harness lever that works the slackener. The standard and doup harnesses each require a vertical row of squares to show their operation.

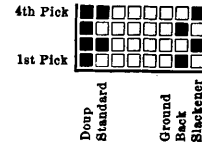

FIG. 15

With Fig. 13 for the harness draft, the gauze weave shown in Fig. 1 is produced by the chain draft shown in Fig. 15. In Figs. 13 and 15, the number of harnesses skipped to allow for the proper crossing of the ends is not definitely indicated, since this varies and does not affect in any way the drawing in and operation of the ends. It will be well to keep in mind the fact that, although the harness and chain drafts show the working of 8 ends for 4 picks, the weave itself is complete on 2 ends and 2 picks.

TOP DOUPS

17. While all the explanations given have referred to the production of plain gauze by means of bottom doups, it is also possible to produce plain gauze on a close-shed dobby by using **top doups**, or doups that are attached to the upper part of the doup harness. Top doups have certain advantages and disadvantages in weaving leno fabrics on open-shed dobbies, which will be considered later in their proper place.

So far as the weave itself is concerned, there is no face or **back** to a plain gauze fabric, since both sides appear alike

The interlacing of the doup end when one side of the cloth is viewed is the same as that of the ground end when the other side is examined. As the interlacings are the same, the deflection of the doup and ground ends from a straight line is equal. Therefore, a study of the use of top doups will show that although in weaving the cloth in the loom the relative positions of the doup and the ground ends are reversed, the product will be a cloth that when turned over will show the same interlacings of both the doup and ground ends as in the cloth woven with bottom doups. In the fabric woven with top doups, the same similarity in appearance of the two sides will be noticed as was observed in the fabric woven with bottom doups. It is thus apparent that it is impossible to tell from a sample of a pure gauze fabric whether it was woven with top or bottom doups, or right- or left-hand doups; these particulars can only be told when it is known which side of the fabric was uppermost in the loom and which end is the doup end.

18. Construction and Arrangement of Harnesses.

The same number of harnesses is required in weaving a plain gauze fabric with top doups as is required for weaving it with bottom doups. The ground and back harnesses are of the ordinary construction. The standard harness, if it carries heddles having both eyes of the same size, is also the same as when used in connection with bottom doups, but if, as is sometimes the case, it carries heddles having eyes of unequal size, these are reversed, so that the large eye is the lower, and their action in conjunction with the top doup, therefore, will be the same as when used with the large eye uppermost, as with bottom doups. The doup harness is constructed the same as when used with a bottom doup, with the exception that the doup is attached to the top of the harness frame instead of to the bottom. The doup and standard harnesses are connected by carrying one end of the doup through one eye of the standard heddle, then back through the other, and fastening both ends of the loop at the top of the doup-harness frame. When top doups are under consideration, a left-hand

doup is one in which the loop of the doup is at the left of the standard heddle, and a right-hand doup, one in which the loop is at the right of the standard heddle, exactly the same as in the case of bottom doups. The harnesses are arranged in the same order as already described for bottom doups—the doup harness at the front of the loom, the standard harness next, then the ground harness, and finally the back harness at the rear. The construction and arrangement of harnesses just described is shown in Fig. 16.

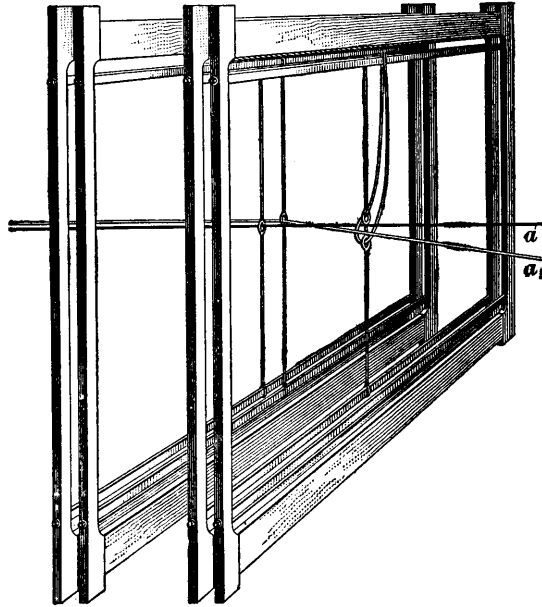

FIG. 16

The doup and ground ends are drawn through the harnesses when top doups are used in exactly the same manner as when bottom doups are employed, with the one exception that when top doups are used, the ground end must be crossed under the doup end instead of over it, as is the case with bottom doups.

19. Operation of Harnesses.—An understanding of the operation of the harnesses when weaving plain gauze with

bottom doups will enable one to comprehend readily their operation when producing the same cloth with top doups. When top doups are used to weave gauze, the doup end remains down and the ground end is raised on every pick.

If the doup end *a*, Fig. 16, is to be depressed under the first pick on the left of the ground end *a*₁, it is necessary that the back harness and the doup harness be left down, the

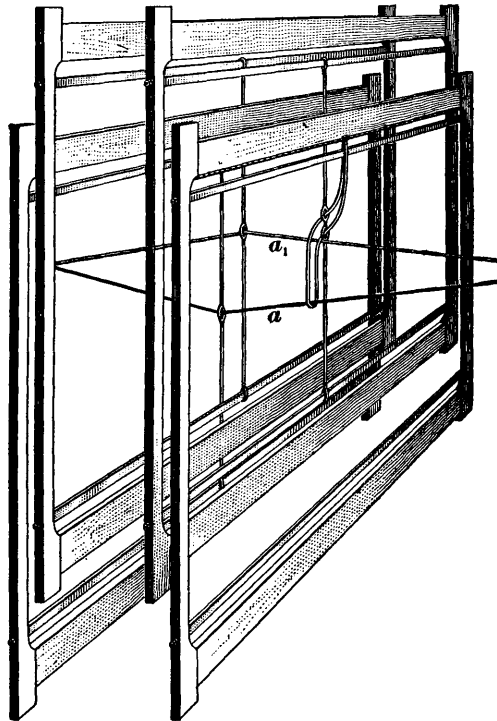

FIG. 17

doup slipping through the eyes of the standard heddle and allowing the back harness to retain the doup end *a* at the bottom of the shed as the standard harness is raised. The ground end *a*₁ is raised by lifting the ground harness, but in order that this may be done the standard harness must also be raised, allowing the ground end to rise between the doup and the standard heddle. The positions of the harnesses

and ends to form the shed for this pick are shown in Fig. 17. After the pick has been inserted, the harnesses are brought level at the bottom of the shed, as shown in Fig. 16.

On the next pick, the doup end a must be down on the opposite side of the ground end a_1 . In order to accomplish this result, the doup and standard harnesses must remain

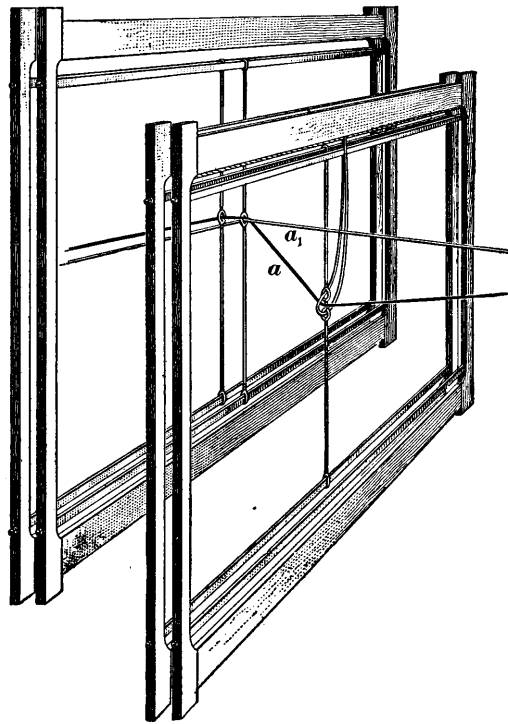

FIG. 18

down. Since on this pick the doup end a crosses the ground end a_1 , which is raised by lifting the ground harness, the back harness must also be raised to avoid straining the doup end. As the crossing of the ends occurs on this pick, the doup end a must be eased by the operation of the slackener. Fig. 18 shows the position of the harnesses and ends on this pick. The leveling of the harnesses at the bottom of the

shed brings them into position for another repeat of the weave; the weave is completed by the 2 picks described.

20. The Weave.—Since the method of operating the doup and ground ends when using top doups differs from the method necessary when using bottom doups, the representation of the working of these ends, or the weave, will also differ. In the case of bottom doups, the representation of the weave, Fig. 12 (c), shows the doup end above every pick and crossing below the ground end between picks. With top doups the positions of the doup and ground ends are reversed, so that the

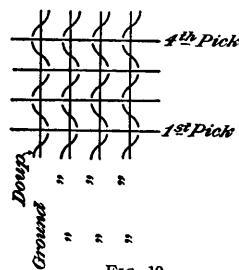

FIG. 19

representation of the weave must show the doup end below every pick and crossing above the ground end between picks. Fig. 19 illustrates the method of representing the gauze weave shown in Fig. 1 if it is woven with top doups. It must be remembered, however, that if Fig. 1 is considered as being

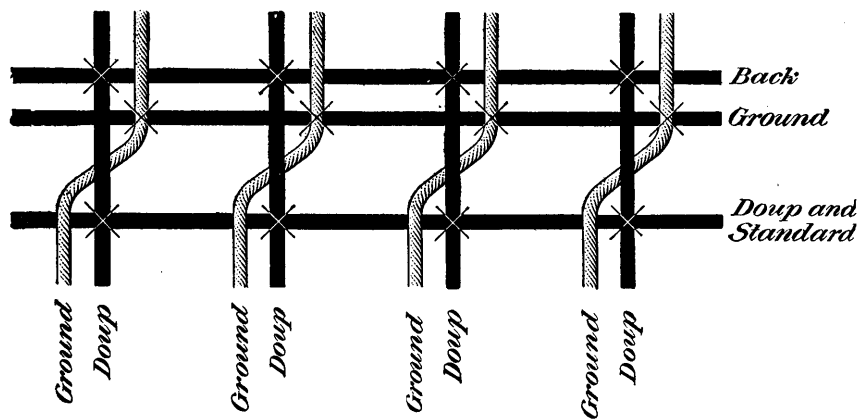

FIG. 20

woven with top doups the end a_1 represents the doup end, since when top doups are used the doup end is below every pick, and also that the end a is the ground end, which is raised over every pick.

21. The **harness draft** for top douns is made on the same principle as that explained for bottom douns and shown in Fig. 13. The only change that must be made is to indicate that in drawing in the ends the doup end must be crossed above the ground end. Fig. 20 is the harness draft for the 8 ends shown in Fig. 1 with the harnesses arranged for top douns, as in Fig. 16. The more simple harness draft made on the principle exemplified in Fig. 14 can easily be changed to apply to top douns by merely indicating on the draft that the doup end is crossed over the ground end when drawing in the warp instead of under it, as in the case of bottom douns.

22. The **chain draft** for top douns, giving the lifting of the harnesses on different picks, is made according to the method explained for bottom douns and shown in Fig. 15. When weaving with top douns, however, the doup end is below every pick that is inserted, whereas in the case of bottom douns its position is above every pick. It is therefore evident that in order to produce the same cloth with top douns as with bottom douns, the operation of the harnesses must be reversed.

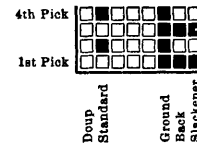

FIG. 21

If on any pick the doup end is to remain down in its normal position, the doup and back harnesses are not lifted, but the standard and ground harnesses are. On the next pick, the doup end must be crossed over and depressed on the other side of the ground end, so that the doup and standard harnesses remain down and the ground and back harnesses are raised. As the crossing of the ends occurs on this pick, the slackener must be operated. After the insertion of this pick, the harnesses are returned to the bottom of the shed, ready for the next repeat of the weave. According to this method, Fig. 21 is the chain draft, which must be used in connection with the harness draft given in Fig. 20 in order to produce the fabric shown in Fig. 1.

23. There is only one noticeable advantage that top douns have over bottom douns in weaving plain gauze; that

is, that they are more easily repaired or replaced. As top douns are attached to the upper part of the doun harness, they are easily accessible for repairs or replacement; but in order to put in new bottom douns it is necessary for the weaver to reach down through the warp ends to attach the loops to the bottom part of the doun harness.

For reasons that will be given later, bottom douns are in more common use in weaving leno fabrics, so that all references in this Section, unless otherwise stated, should be understood to apply to them.

PLAIN GAUZE ON OPEN-SHED LOOMS

ADDITIONAL MECHANISMS REQUIRED

24. The description given so far refers to the weaving of plain gauze on a single-lift, or close-shed, doobby, in which all the warp ends are level at the bottom of the shed after the insertion of each pick. An understanding of the explanations that have been given will show that in order to make the crossing of the ends required in weaving plain gauze, it is necessary to have the doun and the ground ends level between the insertions of successive picks. This point need not be considered when weaving gauze with a close-shed doobby, for on such a loom all the ends are lowered after each pick.

When gauze is to be woven on a double-lift, or open-shed, doobby, this point is important, as it necessitates the use of extra mechanisms to bring the doun and ground ends level after the insertion of each pick. On such a loom, an end in the top shed is never lowered until it is required in the bottom shed on the next pick, and an end in the bottom shed is never raised unless it is required in the top shed on the following pick. As the standard and back harnesses are alternately raised and lowered on successive picks, their operation presents no difficulty with this type of loom. Since, however, the doun end is raised and the ground end depressed on every pick, additional mechanisms are applied to an open-shed doobby to raise the ground harness and lower

the doup harness to the center of the shed and return them to their original positions between the insertions of successive picks of filling, so that the ground and doup ends may meet and cross each other and then return to the bottom and top sheds, respectively. Two devices are used to enable the crossing of the doup and ground ends to take place; namely, the *jumper*, to operate the ground harness, and the *yoke*, to operate the doup harness.

25. The Jumper.—The most practical movement of the harnesses is to move each harness one-half of the full throw, so that the doup and ground ends are leveled at the center of the shed, as previously described. The **jumper** is designed to raise the ground end to the center of the shed and lower it again to its position in the bottom shed between successive picks.

Fig. 22 shows this mechanism. To the dobbie rocker-arm e is attached an arm e_1 , connected by a rod e_2 to a togglejoint e_3 , that is hinged at e_4 . This joint is connected at one end to the dobbie frame at f and at the other end to an arm g attached to the shaft g_1 , to which a segment h is set-screwed. Fastened to the top of the segment is a strap h_1 , connected by a wire h_2 to a loop h_3 , through which the dobbie lever j passes. This loop must be at least equal in length to the distance that the lever will travel in lifting the harness half the distance of the shed, so as to allow h_3 to move as desired in weaving without interfering with the lever j , which, when plain gauze is being woven, is stationary. This arrangement of the dobbie lever and the loop h_3 allows the lever to raise the ground harness, to which h_3 is connected in the ordinary way, to the top shed, as is often required when weaving fancy gauze, or leno, patterns, in the manner to be described later.

The dobbie operates in such a way that the top and bottom arms of the rocker e move alternately outwards and inwards on successive picks. This motion is such that e_2 has a vertical movement, being raised on one pick and lowered on the next pick. Fig. 22 shows the position of the dobbie

when the shed is formed and the rod e_2 is in its lowest position. As the rocker moves so as to form the next shed, the rod e_2 rises until it occupies, at the central point of its rise, the position shown in dotted lines. This movement has forced the togglejoint e_3 and the arm g into the positions shown by dotted lines. Since g and h are both fastened to g_1 , the segment h has been moved to the right, thus lifting

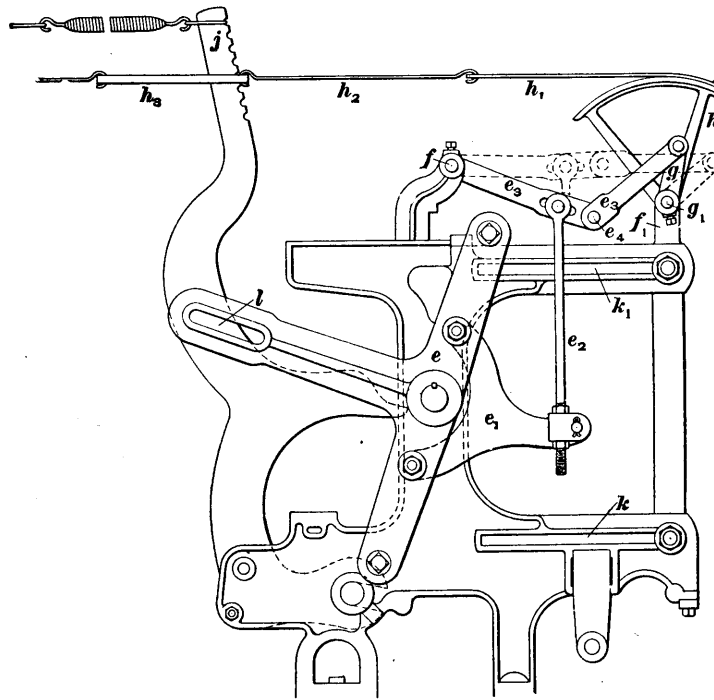

FIG. 22

the ground harness half the height of the shed. As the rod e_2 continues to rise, it will push the togglejoint e_3 still higher, but after it has passed its central position, it will draw the arm g to the left, causing the segment to move in the same direction, so that when the rod e_2 has reached the limit of its upward throw, the segment has reached its former position and lowered the ground harness to the bottom shed.

During the movement of the dobby, a new shed has been formed for the next pick, so that it will be evident that the desired result—that of raising the ground harness to the center of the shed and lowering it again—has been accomplished in the same time that it takes for a harness to change from one shed to the other. From this description it is evident that on the next pick the movement of the segment and, consequently, of the ground harness will be the same as that already described, although in this case the rod e_2 will move downwards. The jumper thus gives automatically all the movement required by the ground harness, bringing it from the bottom shed to the center and lowering it again between successive picks. Sometimes a spring, as shown in Fig. 22, is attached at one end to the dobby lever j and to the upper part of the frame of the loom at the other end, by means of a cord or strap. This keeps the dobby lever in place when the jumper is in operation.

26. The Yoke.—In weaving plain gauze on an open-shed loom, the doup end must also receive a movement equal to half the height of the shed, being lowered from the top shed to the center, to meet and cross the ground end, and then raised again between the insertions of successive picks. The device by which this movement is accomplished

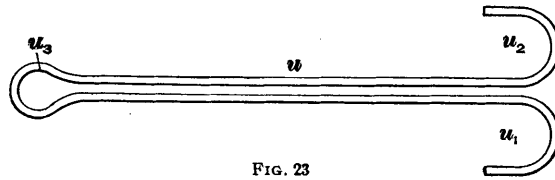

FIG. 23

is called the **yoke** and is shown in Fig. 23. The regular harness straps are attached to the doup, or first, harness, but these, instead of being fastened to the harness lever, are attached to the loop u_2 of the yoke. The hook u_1 is held in one of the notches of the first harness lever by the springs attached to the bottom of the harness. The standard harness is attached to the second lever of the dobby in the ordinary manner.

27. In weaving gauze, the doup harness is raised without the standard on the first pick, and the doup and standard harnesses are both lifted on the second pick. The first lever is operated in the ordinary manner, and in rising it carries with it the hook u_1 , thus raising the doup harness.

On the second pick, on which the doup and the standard harnesses are raised, the second lever must be raised, thus raising the standard harness in the ordinary way; on this pick the first lever is lowered. As the lever moves down, it allows the yoke to move and lower the doup harness. When, however, the lever has reached the center of its throw, the second lever, which is rising, catches in the hook u_2 and, by carrying back the yoke, raises the doup harness to its former position in the top shed.

On the next pick, the harnesses must be brought to the position described for the first pick; this is accomplished by raising the first lever and lowering the second lever. When the yoke has lowered the doup harness to the center of the shed, by the lowering of the second lever, it is caught by the first lever as it is rising and raises the doup harness to its position in the top shed. From this description of the action of the yoke it will be evident that the doup harness will be up on every pick, but between successive picks will drop to the center of the shed and rise to the top shed again.

Thus the jumper and yoke give to the ground and doup harnesses the peculiar motions that are necessary if plain gauze is to be woven on an open-shed dobby. These movements of the harnesses, by raising the ground end and lowering the doup end, bring the ends level at the center of the shed, allowing the crossing to take place, and then carry the ends back to their original positions in time for the insertion of the next pick. This whole operation is accomplished in the same time that would be required for a harness operating in the ordinary way to move from the top to the bottom shed, or vice versa.

28. Harness and Chain Drafts.—When plain gauze is woven on an open-shed dobby with the jumper and yoke

attachments, the warp is drawn through the harnesses exactly the same as though a close-shed dobby were used; that is, the harness draft is the same in both cases.

The chain draft, however, is different from that used on a close-shed dobby. The jumper gives automatically the necessary movement to the ground harness, so that in making the chain draft for weaving plain gauze on an open-shed dobby, the squares that correspond to the ground harness require no marks. In making a gauze fabric on the machine under consideration, the ground harness need not be connected to any harness lever. It is usually so connected, however, when weaving fancy gauze, or leno, in the manner to be described later, in order to allow the ground end to be raised above the pick, as required, independently of the action of the jumper. The harness to which the jumper is connected is sometimes indicated on the chain draft, often by the letter *J* above the row of squares devoted to that harness.

With an open-shed dobby the working of the doup harness must be indicated in a different manner from that used for a close-shed dobby. If the doup harness were marked as in the latter case, it would remain in the top shed and the ends could not cross. If, however, the lever operating the doup harness is raised only on alternate picks, and the lever operating the standard harness is raised on the other picks, the doup end will be lowered between picks, so as to allow the crossing to take place, and will be raised on every pick by the yoke, which is alternately raised by the doup and the standard levers. The doup harness, therefore, on an open-shed dobby should be marked to rise only on alternate picks, since the standard lever, by means of the yoke, will raise it on the other picks.

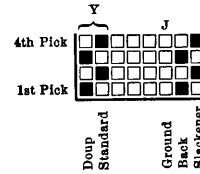

FIG. 24

The chain draft required for weaving the gauze shown in Fig. 1 on an open-shed dobby is given in Fig. 24, in which one method of indicating the harnesses connected by the yoke is shown; that is, by the letter *Y*.

GENERAL CONSIDERATIONS

29. In considering the weaving of plain gauze with top doups, the statement was made that so far as the weave or appearance of the cloth is concerned, it is impossible to distinguish the face from the back of the fabric. Theoretically, however, the side of the fabric that shows the doup end above the ground end between picks is the face. This, of course, is the side of the cloth that is undermost in the loom when the cloth is woven with bottom doups and uppermost when top doups are used. The reason for this designation is that the doup end by being often drawn considerably out of a straight line in fancy gauze weaves, because of its crossings, forms a distinct pattern on one side of the cloth, which is not produced on the other side, this side being therefore called the face, although in the case of bottom doups it is the side that is undermost in the loom. This difference between the two sides of the fabric will readily be discerned when fancy gauze, or leno, weaves are considered.

From this designation it will be evident that if the gauze shown in Fig. 1 was woven with bottom doups, *a* is the doup end and the cloth is woven face down; if it was woven with top doups, *a*, is the doup end and the cloth is woven face up. In weaving fancy gauze it is an advantage to weave the cloth face side up, since in this way it can readily be seen if the pattern is not weaving properly; but as top doups cannot be used for weaving all fancy gauze, or leno, fabrics, bottom doups are more commonly employed and the cloth, therefore, woven face down in the loom. In weaving plain gauze, however, there is no advantage in top doups in this connection, since both sides appear alike and broken ends are readily detected. Therefore, the only important advantage of top doups in weaving plain gauze is the ease with which they can be replaced when broken; and both top and bottom doups may consequently be used with little discrimination in such weaving on a close-shed loom.

In weaving plain gauze on an open-shed dobby, the only advantage of top doups would still be their easy replacement.

As this advantage is so slight and their use on an open-shed loom would necessitate the use of mechanisms different from the yoke and jumper used with bottom doups, in order to allow the doup and ground ends to cross between successive picks, top doups are seldom, if ever, used in weaving plain gauze. These remarks concerning the use and limitations of top doups in weaving plain gauze apply equally well to plain gauze when combined with other weaves, as described later in the consideration of fancy gauze.

Since there are no mechanisms in general use by means of which plain gauze may be woven with top doups on an open-shed loom, the use of these doups on such a loom is practically limited to those varieties of fancy gauze that can be woven on the same loom by bottom doups without the aid of the yoke and jumper; that is, those weaves in which there is at least 1 pick inserted between the picks on which the doup end appears on opposite sides of the ground end.

30. A careful consideration of top and bottom doups will make it evident that any gauze, or leno, weave that can be woven with top doups on either a close- or an open-shed loom can be woven with bottom doups, but that the use of top doups is limited to weaves produced on a close-shed loom or to those woven on an open-shed loom in which the doup and ground ends are not required to cross between successive picks. Because of their greater possibilities in leno weaving, bottom doups are in more general use than top doups.

Although the references made in the following treatment of fancy gauze will be understood to be to bottom doups unless otherwise specified, a knowledge of the facts just presented should enable the possibilities of reproducing the weaves shown with top doups to be determined.

FANCY GAUZE, OR LENO

METHODS OF PRODUCING FANCY GAUZE EFFECTS

31. In weaving plain gauze, the main object attained is the production of a fabric characterized by its open, or lace-like, appearance and by its great strength in proportion to its weight. In such a cloth the twisting of the ends does not produce a pattern, or a figured appearance. Fancy gauze, however, while it retains these features in a lesser degree, is characterized chiefly by its pattern, or figured appearance, produced by enlargements or variations of the plain gauze weave combined with each other or with weaves produced by the ordinary method of weaving. A sufficient number and variety of fancy gauze weaves will be here illustrated and explained to give an understanding of the methods employed in producing the almost unlimited number of different fancy gauze, or leno, patterns that are met with.

COMBINATION OF RIGHT-HAND AND LEFT-HAND DOUPS

32. One of the most effective as well as one of the simplest methods of producing fancy gauze, or leno, designs consists of varying the manner of drawing in the doup ends; that is, drawing a part of the ends through right-hand doups and others through left-hand doups. For illustration, suppose that the entire warp is composed of doup and ground ends, the doup ends being drawn through right-hand and left-hand doups alternately; then the drawing-in draft will be similar to that shown in Fig. 25, in which 4 ends constitute one repeat of the draft. Considering the ends in the order in which they are drawn through the back and ground harnesses, the first end at the left is a doup end, which is drawn through the back harness, then crosses under the

ground end, and is drawn through a left-hand doup. The second and third ends are ground ends, but the fourth end, which is the second doup end, is drawn through the back harness, crosses under the ground end, and is then drawn through a right-hand doup. Thus, while the first doup end is drawn through a left-hand doup, the second doup end is drawn through a right-hand doup. If, when weaving the

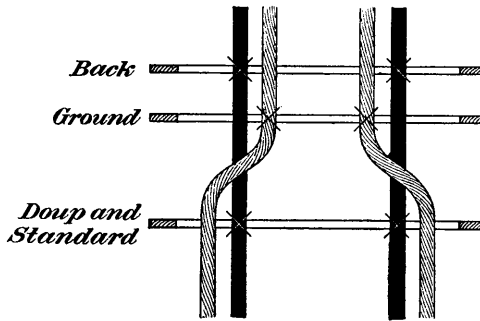

FIG. 25

cloth with the ends drawn in after the manner shown in Fig. 25, the ends doup on every other pick, as in pure gauze, the effect produced in the cloth will be similar to that shown

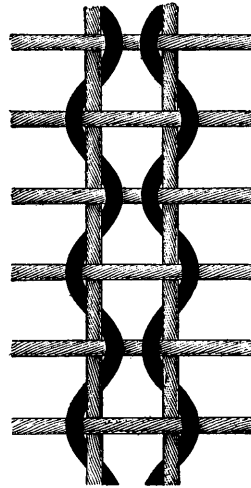

FIG. 26

in Fig. 26, where it will be seen that when one doup end is brought up on the right of its ground end, the other is brought up on the left of its ground end. When it is stated, as in the above case, that the ends doup on a certain pick, it is meant that on this pick the doup and standard harnesses are raised together so that the

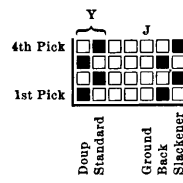

FIG. 27

doup end crosses the ground end and is raised on the opposite side from that on which it would be raised normally by the back harness.

The chain draft that would be used in producing the weave shown in Fig. 26, considering that the cloth is woven on an open-shed dobby, is shown in Fig. 27. On the first pick, the doup and back

harnesses are raised, which will have the effect of raising all the doup ends. As shown in the drawing-in draft, Fig. 25, the first doup end is drawn through a left-hand doup; therefore, when the doup and back harnesses are raised, this end will be brought up on the left of its ground end; this is the effect shown in Fig. 26. The second doup end is drawn through a right-hand doup; therefore, when the doup and back harnesses are raised together, this end will be brought up on the right of its ground end, as shown on the first pick in Fig. 26. On the second pick, as shown in Fig. 27, the back harness remains down, while the doup and standard are raised, the doup being raised by the yoke as the standard goes up. In this case the doup end drawn through the left-hand doup will be brought up on the right of its ground end, while the doup end drawn through the right-hand doup will be brought up on the left of its doup end; this is the effect produced on the second pick, as shown in Fig. 26.

All figures used to illustrate the effect of a leno draft in the cloth can give merely an idea of the manner in which the ends will interlace with the filling, since in almost every case where a fancy leno effect is produced, the picks as well as the ends are so pulled out of a straight line that it is rather difficult to represent them by the ordinary methods.

EFFECTS FORMED BY INSERTING TWO OR MORE PICKS BEFORE DOUPING

33. Fig. 28 shows another method of forming fancy leno effects, in which the doup end is made to cross several picks before the doubling takes place. Thus, considering the bottom pick of Fig. 28 as the first pick of the weave, it will be seen that on the first 4 picks the doup end is brought up on the left of the ground end; on the next 4 picks it is up on the right of the ground end; while on the last 4 picks it is up on the left of the ground end. It is not necessary, of course, to have exactly this order of interlacing these 2 ends, since the doup end may be made to cross as many picks before doubling as may be desired, it simply being necessary to build

often combined in the same cloth to produce another effect. This will be found to be true with all the weaves that will be explained, and although examples of every case may not be given, it should be understood that their combination is nevertheless possible.

WEAVES IN WHICH THE DOUP AND GROUND ENDS
WORK PLAIN

35. Fig. 30 shows a weave in which the ground and doup ends are made to work plain for a certain number of picks and then caused to doup. Fig. 31 shows the chain draft for this weave. On the first pick, as shown in the chain draft, the ground harness is lowered, while the doup and back harnesses are raised, thus causing the doup end to be over, and the ground end to be under, the pick of filling. On the second pick the doup, standard, and back harnesses are lowered, while the ground harness is raised by lifting the dobbie lever to which it is attached by the lever extending through the long loop that is a part of the connection between the ground harness and the segment of the jumper arrangement. Thus, on this pick the ground end will be over, and the doup end under, the pick of filling, producing a plain weave. The third pick is like the first, but on the fourth pick the doup and standard are raised, the ground and back harnesses are lowered, and the slackener is operated, thus producing a crossing of the ends. The next 2 picks are simply a repetition of the first 2 picks.

Left-hand doups are used in this case, since the doup end is brought up on the right of the ground end when the douping takes place. Right-hand doups, however, could be used just as readily, and this will be found to be true of any illustration shown; that is, the crossing may be made either from right to left or from left to right, provided that the ends are

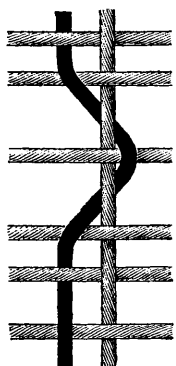

FIG. 30

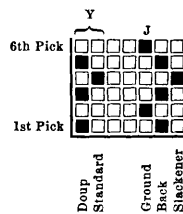

FIG. 31

drawn in such a manner as to meet the desired requirements. With weaves similar to that shown in Fig. 30, the doup end should always be over the filling on the pick immediately preceding and following the pick on which the crossing takes place. Thus, in Fig. 30, on the fourth pick the douping takes place; consequently, on the pick immediately preceding this pick, or the third, the doup end is over the pick of filling. The same is true with regard to the fifth pick, which is the pick following the one on which the douping takes place. This point must always be considered when making a leno weave in which the doup and ground ends work plain throughout a part of the pattern.

36. Harness Draft.—When it is desired in a combination of several ground ends with 1 doup end to have the ground ends work plain during a part of the weave, it is necessary to draw each end that works differently through a separate ground harness. If, however, it is desired to use these ground ends simply for the purpose of letting them all make a turn with the doup end at the same time, they may be drawn through the same harness, since they may be operated as a single end.

**WEAVES PRODUCED BY TWO OR MORE DOUP ENDS OR
TWO OR MORE GROUND ENDS**

37. Fig. 32 illustrates the manner in which the doup end may be made to cross more than 1 ground end and yet have all the ends in the weave work plain in those parts of the fabric where it is desired to produce plain cloth. On the pick on which the douping takes place the doup end crosses 3 ground ends; therefore, in the drawing-in draft the doup end must be drawn in such a manner that it will pass under 3 ground ends between the back harness and the doup and standard harnesses. Again, since there are 3 ground ends crossed by the doup end, these 4 ends must be drawn together in the same dent, in order to produce a crossing in front of the reed.

Noticing next the ground ends, without reference to the doup end, it will be seen that in that part of the weave that works plain, the first ground end, or the second end in the

illustration, works differently than the second ground end, while the last end works the same as the first ground end; consequently, while the first and third ground ends can be drawn through the same harness, the second ground end will

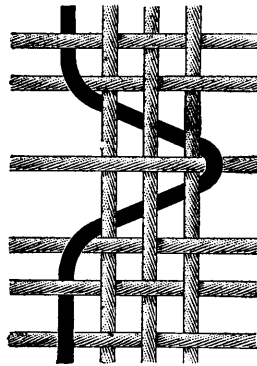

FIG. 32

have to occupy a separate harness, thus necessitating the employment of 2 ground harnesses. From this it will be seen that if the 4 ends shown in Fig. 32 constitute one repeat of the weave, the necessary harnesses to produce this weave given in the order in which they come in the loom will be as follows: Doup and standard harnesses, first ground harness, second ground harness, back harness.

38. Considering the manner of drawing in the different ends, the doup end is drawn through a left-hand doup; in drawing in this end, it will first be drawn through the back harness and then through the doup harness. The first ground end will be drawn through the first ground harness, crossed to the left over the doup end, and drawn through the same dent as the doup end. Since the second ground end works differently from the first, it will be drawn through the second ground harness, crossed over the doup end, and passed through the same dent. As the third ground end works the same as the first, it will be drawn in similarly to that end. This completes one repeat of the drawing-in draft, which is shown in Fig. 33.

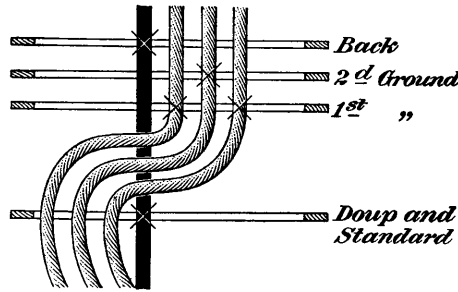

FIG. 33

39. Chain Draft.—In weaves similar to that shown in Fig. 32, it is customary to work both ground harnesses with

the same jumper attachment, but at the same time to have each harness connected to its individual lever, in order that each may be lifted in plain order when desired. The following is as simple a rule as any to follow when making a chain draft for these weaves. On the picks that are to work plain have the levers that work the ground harnesses lifted and lowered as they would be when producing a plain weave; on those picks on which the douping takes place have all the levers that work the ground harnesses lowered, since on these picks the jumper will perform all the necessary work. Fig. 34 shows the necessary chain draft for this weave. On the first pick the doup and back harnesses are raised, thus bringing the doup end over the pick of filling. On this pick, also, the first ground harness is lowered, while the second ground harness is raised. Since the first and third ground ends are drawn through the first ground harness, and this harness is lowered on this pick, these ends will be under the pick of filling. Since the second ground end is drawn through the second ground harness, which is raised on this pick, the second ground end will be over the pick of filling, as shown in Fig. 32.

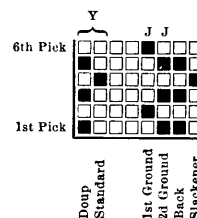

FIG. 34

On the second pick, as shown in the chain draft, the only harness that is raised is the first ground harness, and since the first and third ground ends are drawn through this harness, these ends will be over the pick of filling, while the other ends will be under the pick of filling. The third pick is the same as the first.

On the next pick, however, the standard and doup harnesses are raised—the latter by the yoke—and the slackener is operated, thus bringing the doup end up on the right of the 3 ground ends and causing a turning of the ends. When causing a turn in the ends on an open-shed dobby, it is necessary to bring all the ends level at about the center of the shed. With the weave being illustrated, this is accomplished as follows: On the third pick the doup end is over the pick of filling, which is in accordance with the instructions

previously given that the doup end should be over the filling on the picks immediately preceding and following the pick on which the douping takes place. On the fourth pick the doup and back harnesses are lowered, which causes the doup end to drop, but the standard harness is raised. As the lever operating the standard harness rises, it will catch the hook attached to the doup harness when the doup end has dropped half the space of the shed, and thus this end will be brought from the top of the shed to the center and then back to the top again.

Considering next the first and third ground ends, which work alike and are therefore drawn through the same harness, it will be seen that on the third pick they are both down; consequently, on the fourth pick some means must be adopted to bring them to the center of the shed and then lower them again. According to the chain draft, on the fourth pick the lever operating the first ground harness through which these ends are drawn is not raised; but, since this harness is also attached to the jumper, it will be under the control of this mechanism when not lifted by its lever, and will therefore be brought to the center of the shed and then lowered to the bottom. On the third pick the second ground end is raised, while on the fourth pick it is lowered; consequently, in passing from the top of the shed to the bottom, it will necessarily meet the other ends at the center. It is in this manner that on the pick on which the douping takes place the doup end and the ground ends are brought level at the center of the shed, permitting the crossing of the ends. The fifth and sixth picks are similar to the first and second, respectively.

40. The weave shown in Fig. 32 is typical of a large variety of weaves in which 1 doup end crosses 2 or more ground ends. Though the variations in the interlacings of these ends are many, they present no difficulties to one who understands the method of reproducing the weave given in Fig. 32.

Weaves of this character might be made by having 2 or more doup ends drawn through separate back harnesses,

under 1 ground end, and through the same doup, but as this method is not as convenient as that just described, it is not used to any extent.

41. A common method of obtaining leno effects is by a combination of the two methods just mentioned; that is, by having 2 doup ends drawn through 2 back harnesses, under 2 ground ends, which are drawn in 2 harnesses, and then through 1 doup harness at the front. A leno pattern obtained in this way is shown in Fig. 35, the harness and chain drafts being given in Figs. 36 and 37. The pattern is complete on 8 picks, though in Fig. 35 the first pick is repeated, in order to show the complete working of the ends. In this system, it is evident that as the doup ends are both drawn through the same doup, which is raised by the standard harness when

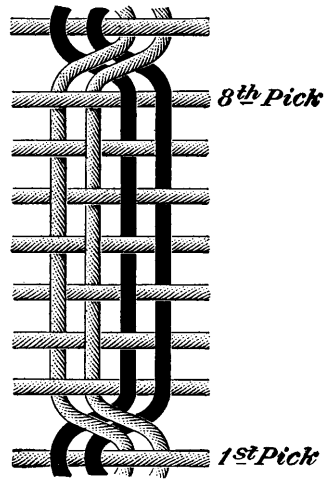

FIG. 35

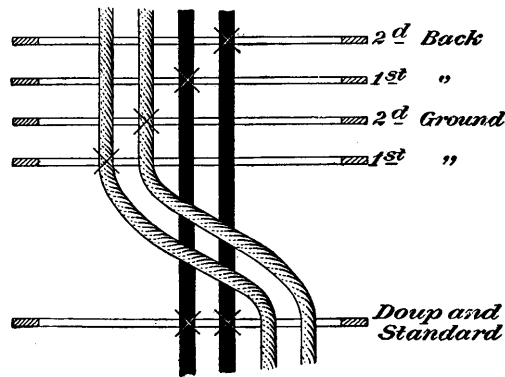

FIG. 36

the douping takes place, these ends must be raised together when this action occurs. Though the doup ends are thus limited when raised out of their normal position the ground

ends are not restricted and may be operated separately as desired on all douping picks; it is seldom, however, that the ground ends are worked separately on such picks, it being customary, in order to bring out the full effect of the crossing of the ends, to depress both ground ends on the pick, or picks, inserted when the doup ends are raised out of their normal position. When the doup harness is raised and the standard harness remains down, the doup ends can be raised independently of each other and of the ground ends, since they are raised in their normal position, and as the ground ends can also be operated independently, all 4 ends can be utilized to weave plain cloth as shown in Fig. 35, picks 3 to 7, inclusive.

This weave necessitates a different use of the yoke from that explained in connection with the weaving of gauze on

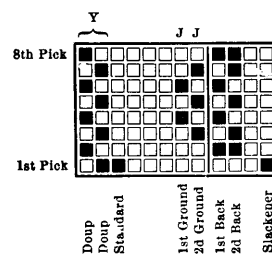

FIG. 37

an open-shed dobby, where the doup harness is readily operated so as to prevent any great amount of slack in the doup, which slackness would be liable to entangle and break the ends. If the 2 doup ends, which are drawn through the same doup, as shown in Fig. 36, worked alike throughout the weave, as they do on the first 2 picks of the weave shown in Fig. 35, the

arrangement of the yoke connected with the doup and the standard harnesses would be the same as that used in weaving plain gauze on an open-shed loom with 1 doup end crossing 1 ground end. When, however, as in this case, the doup ends drawn through the same doup work differently, two levers are required to operate the doup harness, while the standard harness is operated by the third lever, to which it is attached in the ordinary manner. As has been stated, the first 2 picks present no difficulty, because the doup ends work alike, so that if the doup harness is worked correctly as for 1 doup end, the doup will remain practically taut throughout its movement. On the third pick, 1 doup end is depressed, but the other doup end is raised and retains the doup in position; consequently, no difficulty is

experienced on this pick. On the fourth pick, however, the positions of the doup ends are reversed; as the end that was raised on the previous pick descends, it will allow the doup to become slack until it meets, at the center of the shed, the other doup end, which is rising, unless at the same time the doup harness is moved to the center of the shed and returned to the top shed. This movement is the same as that which would be given if the yoke were attached to the levers operating the doup and the standard harnesses; but as the lever operating the standard harness is not raised on the next pick, this arrangement cannot be used.

In order to give the required movement to the doup harness the yoke is connected to the first two levers of the doobby, but is entirely independent of the third lever that operates the standard harness. The yoke, to which the doup harness is connected, is attached to levers that operate in the same way as the doup and standard levers when connected by a yoke, as previously explained. As the doup harness is lowered by one of the levers to which the yoke is attached, the doup is lowered to the center of the shed at the same time that the end previously raised is descending; the doup harness is then raised by the other lever while the end previously depressed is rising; consequently, the doup is kept practically taut, and tangling and breaking of ends is avoided.

In weaves of this character the standard harness is operated as required, independently of the two levers connected by the yoke for the purpose of operating the doup harness. The first two levers are operated alternately on all picks where the doup ends work differently, in order to lower the doup harness to the center of the shed and return it to its position between successive picks. One of the yoke levers should, of course, always be raised whenever the standard is raised to enable the douping to take place.

**EFFECTS REQUIRING MORE THAN ONE SET OF
DOUP ENDS**

42. In many leno weaves, the doubling of one set of ends occurs on one pick while the doubling of another set occurs on another pick. In such cases, it is necessary to employ as many sets of doup and standard harnesses as there are sets of doup ends. Two sets of doup and standard harnesses are the most common, although in some cases more are used. A good plan to follow when seeking to determine the number of ends that doup differently, is first to determine the doup ends in one repeat of the pattern of the weave, and next to follow the interlacings of the different picks and determine

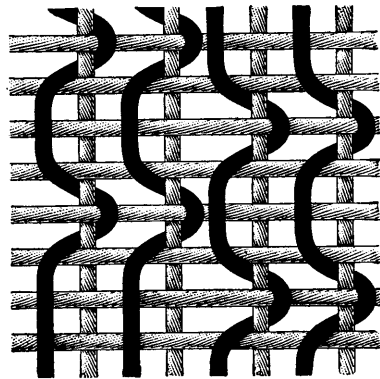

FIG. 38

the number of sets of doup ends that doup on different picks. If one set of doup ends is found to doup on a different pick than the others, those ends require a separate doup, a separate standard, and a separate back harness; that is, there must be as many different sets of these harnesses as there are different sets of doup ends that work differently.

Fig. 38 illustrates this point somewhat more clearly; on the second and sixth picks the third and fourth doup ends doup, while on the fourth and eighth picks the first and second doup ends doup. Consequently, in this weave there are two sets of doup ends, which are actuated by two sets of harnesses; that is, the first 2 doup ends are drawn through one set of harnesses and the last 2 doup ends through another set.

When more than one set of doups are used to weave a fabric, the order in which the harnesses are usually arranged is as follows: doup, standard, doup, standard, and so on, until the number of doups and standards that are required

are used; next follows the ground harness for the end that is crossed by the doup end drawn through the front doup, and next the back harness for that doup end; after this follow the ground and back harnesses for each set of doup and standard harnesses in regular order. This order, although not always adopted, is the general one and will be found to give the best satisfaction.

43. Considering the drawing-in draft for Fig. 38, the first 2 doup ends work alike and also the first 2 ground ends; therefore, one set of doup, standard, ground, and back harnesses will serve for these 4 ends, left-hand doups being used. The third and fourth doup ends, although they work

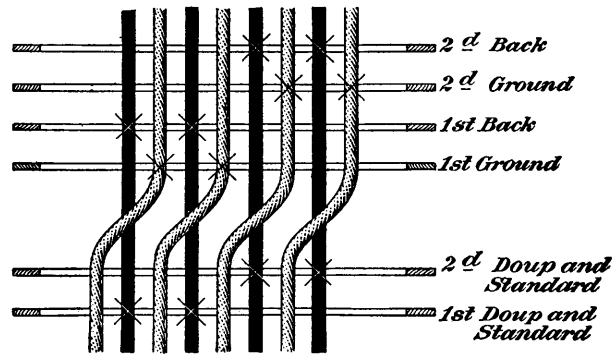

FIG. 39

alike, work in a manner entirely different from the first and second doup ends, and while they may be drawn in similarly to each other, they must occupy a separate set of harnesses from the first 2 doup ends. The same is true of the third and fourth ground ends when considered in relation to their respective doup ends and the first and second ground and doup ends.

The complete drawing-in draft for these ends is shown in Fig. 39; the first doup and standard harnesses, the first ground harness, and the first back harness are used for the first 4 ends of Fig. 38, while the remaining harnesses are used for the second 4 ends. Fig. 40 shows the chain draft that will give the effect shown in Fig. 38 with the ends drawn in

as shown in Fig. 39. Considering the first pick of Fig. 40, the first doup and first back harnesses are raised, which raises the first and second doup ends; the second doup and second back harnesses are also raised, which raises the third and fourth doup ends. As the other harnesses are not lifted on this pick, the remaining ends will be down. On the second pick, the second standard harness is raised, which by means of the yoke raises the second doup harness, causing the third and fourth doup ends to doup. The first doup and first back harnesses are also raised on this pick, which will cause the first and second doup ends drawn through these harnesses to be lifted. The third pick is the same as the first. On the fourth pick, the first standard, and consequently the first doup, harnesses are raised, causing the first and second doup ends to doup. As the second doup and second back harnesses are also raised, the third and fourth doup ends will be up on this pick. The last 4 picks are simply repetitions of the first 4 picks. Each set of doup and standard harnesses must have its own slackener; thus, Fig. 40 provides for two slackeners, one for the first set of doups and another for the second set.

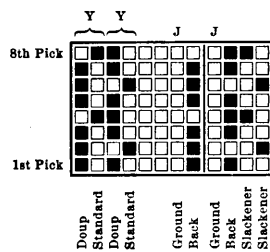

FIG. 40

When the first and second doup threads are made to doup, as they are on the fourth and eighth picks, the first slackener is operated, while the second slackener is operated when the third and fourth doup ends are douped, as on the second and sixth picks. In every case where more than one set of doup ends is adopted there must be a slackener for each set and the doup ends drawn over their respective slackeners.

44. It is possible to weave on a comparatively small number of harnesses a variety of leno effects somewhat elaborate in appearance that seem to require a large number of harnesses for their production. In such weaves separate back and ground harnesses are required for each pair of doup and ground ends that work differently from every other pair.

Only 1 doup and 1 standard harness is used, however, all the doup ends being drawn through doups on the one doup harness, as they all doup on the same picks. Such an arrangement is possible because on every alternate pick the doup and standard harnesses are both raised, while on the other picks the doup harness alone is raised. On the picks first mentioned, every doup end is raised out of its normal position by the lifting of the doup and standard harnesses. On the second pick and every alternate pick, there are two possible manipulations of the ends that work together, so that either the ground end or the doup end may be raised. In the first case the ground end is raised by lifting the ground harness, but as the back harness remains down the doup end is down and, consequently, the doup retains its position, although the doup harness is lifted. In the second case the doup end is raised by lifting the back harness, this being possible because, as already noted, the doup harness is raised on this pick.

If the pick on which the doup end is raised out of its normal position is alternated with the pick on which the ground end is raised, it will result in weaving plain cloth. If the pick first mentioned is alternated with the pick on which the doup end is raised in its normal position, the result will be plain gauze. Since each pair of doup and ground ends is drawn in on separate back and ground harnesses, it is evident that one pair of ends may weave plain cloth and another pair weave plain gauze throughout a repeat of the weave, or that any pair of ends working together may weave plain cloth for part of the weave and plain gauze for the remainder. The latter method is in general use for producing elaborate effects with a relatively small number of harnesses. In such weaves a groundwork of plain cloth is produced by raising the ground ends on those picks where there is a choice in the working of the ends, and the design is made by weaving plain gauze by raising the doup ends on the required number of these same picks.

Fig. 41 shows the weave of a leno design made on this principle, which will give a zigzag effect in the cloth, and

Figs. 42 and 43 show the requisite harness and chain drafts, the latter being for a close-shed loom. The weave is complete on 16 picks, though Fig. 41 gives the last pick of the previous repeat and the first pick of the following repeat of

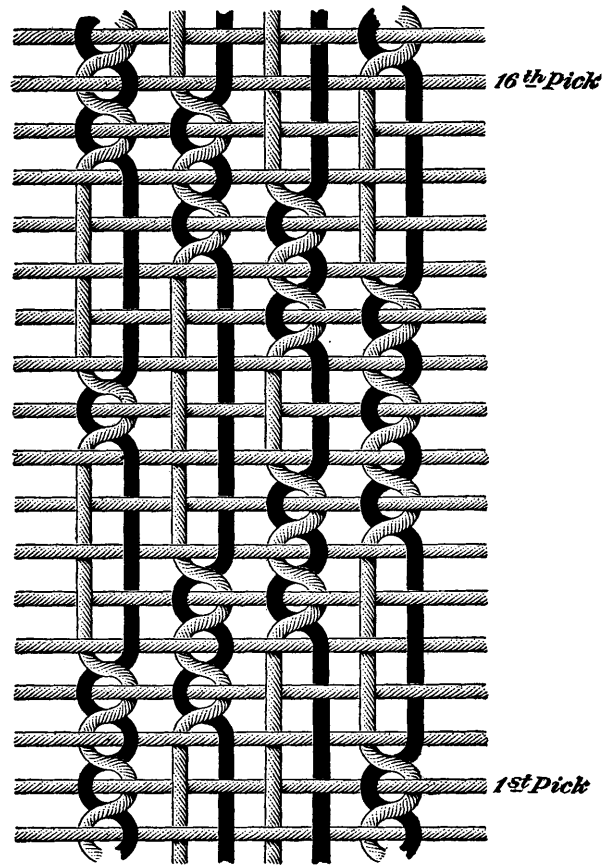

FIG. 41

the weave. This weave shows the features peculiar to leno fabrics woven on this principle with only one set of doup and standard harnesses. On the second and every even-numbered pick, every doup end is raised out of its normal position. On the first and every odd-numbered pick, certain doup ends are

raised in their normal positions, while certain others remain down and the ground ends that work with them are raised.

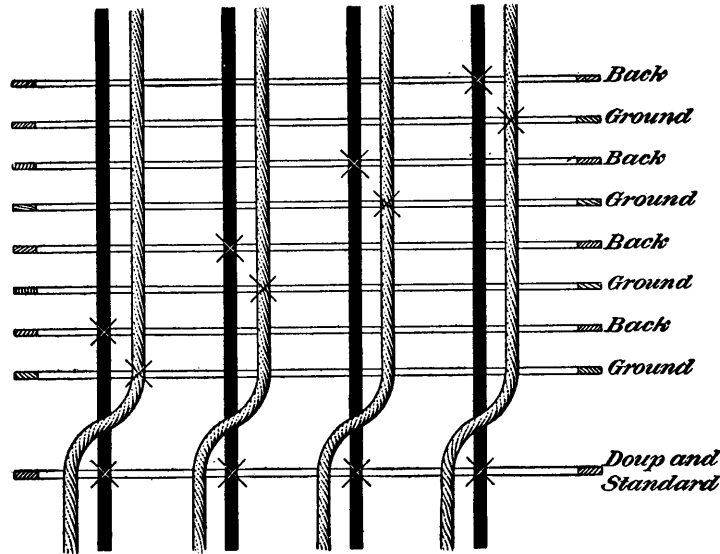

FIG. 42

In either case the ends are raised on the side opposite to that on which the doup ends were raised on the previous pick.

45. A simple and accurate method of making weaves of this character is as follows: Mark on design paper as a motive the effect that is desired. Then on the chain draft allow for 1 doup harness, 1 standard harness, 1 slackener, and twice as many harnesses for the doup and ground ends as there are ends in the motive that work differently; also allow for twice the number of picks required by the motive; the allowance for ends is

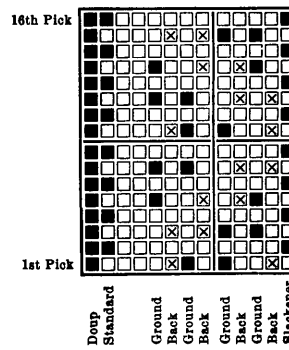

FIG. 43

made because each end of the motive represents 2 ends—a doup and a ground end working together—and the allowance

for picks because in weaving the design all the pairs of ends must weave alike on half the picks. In making the chain draft, mark every alternate pick to raise the doup and the standard harnesses and operate the slackener. These picks will always be marked alike, irrespective of the design, and on these picks no marks are ever placed to operate any of the ground or back harnesses. Next mark the draft to raise the doup harness on all those picks that have not been marked. Since it is on these picks that the choice is given of raising either the ground or the doup ends, and the desired

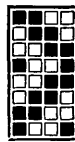

figure is produced by raising certain doup ends so as to weave plain gauze, the design should be marked on the back harnesses on these picks. As the last step, mark the chain draft on these same picks to raise the ground harness of every pair of ground and back harnesses, where the back harness has not been marked to raise the doup end drawn through it. The motive for the weave shown in Fig. 41 is given in Fig. 44, and is shown properly placed on the chain draft by the crosses in Fig. 43.

The principles involved in producing leno effects by this method are fully explained with reference to the weave shown in Fig. 41, which is sufficiently large to give the desired effect on certain classes of goods. On many fabrics, however, it is necessary, in order to bring out the effect to the greatest advantage, to use all the available harnesses for the differently working pairs of ends, and to extend the number of picks proportionately.

COMBINATION LENO EFFECTS

46. Although the illustrations given deal only with doup and ground ends, leno effects are not made up entirely of these, since almost all leno patterns are made by combining a plain or fancy gauze weave with some other weave of ordinary structure, thus forming stripes, checks, and many other effects. With the designs so far given, it has been the object to explain the different leno weaves that are commonly used in combination with some other weave, and it

should be understood that it is possible to combine any of these weaves, or, in fact, several of them, with other weaves, such as plain or twill, and in this manner form numerous and varied effects.

47. When weaving a gauze, the back harness and the harness through which the ground ends are drawn should be placed as near the back of the loom as possible and operated by the back levers of the dobbie, in order to give the doup ends room in which to cross the ground ends. In cases where a leno design is composed of some other weave in addition to the gauze, it is the custom to place the harnesses carrying the ends forming this weave between the standard and the ground harnesses and to have them operated by the center harness levers of the dobbie. In all illustrations given of this class of weaves, this order of placing the harnesses will be observed.

48. Combinations of Plain and Gauze Weaves. Fig. 45 shows a leno design in which the first 24 ends work plain, producing a stripe of plain weave. The remaining ends produce a stripe of gauze, but while some of the ends are douping to the right, others are douping to the left, and as all these ends do not interlace with the filling in exactly the same order, widely varied effects are produced. The first point to determine when reproducing a leno fabric is the number of sets of doup harnesses necessary for the doup ends. When a doup end is found to doup on a pick on which the other doup ends do not, that end must have a separate doup and standard harness. On the first pick shown in Fig. 45, all the doup ends are operated in the same manner; consequently, as far as this pick is concerned, only one doup and standard harness are necessary. The same is true of the second and third picks. On the fourth pick, however, two methods are adopted, since while the first two and also the last two sets of crossing ends doup on this pick, the second two do not, but remain as they were on the third pick; consequently, thus far at least two sets of doup and standard harnesses are necessary. Comparing the interlacings of the

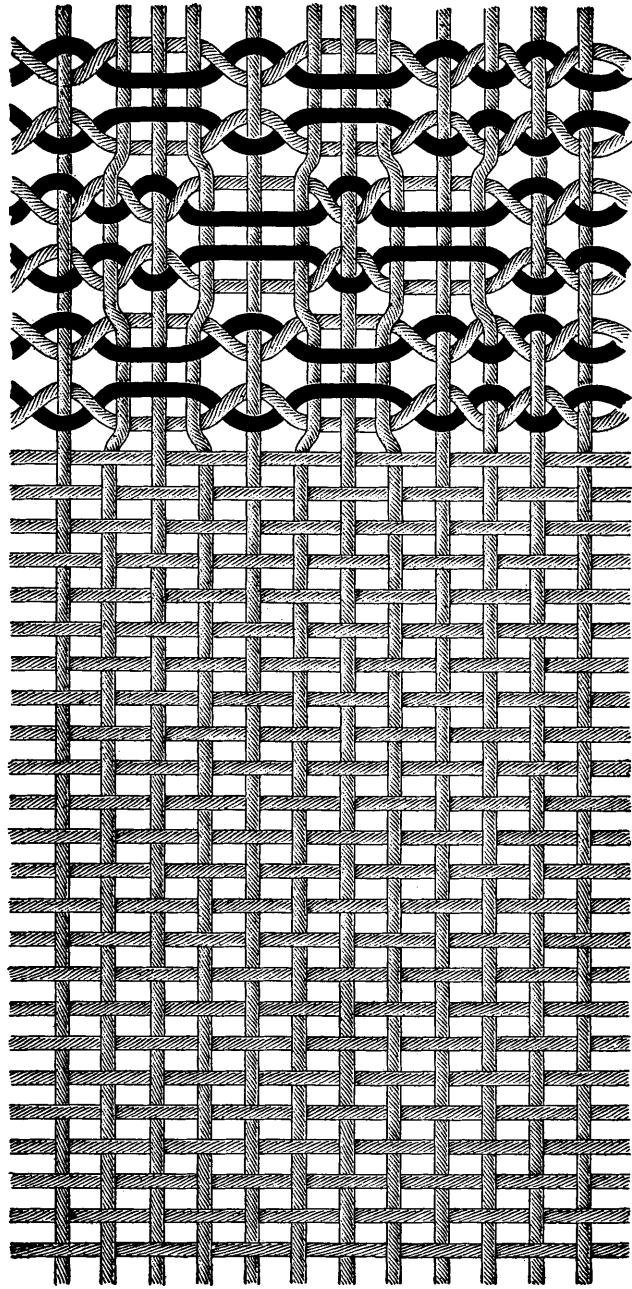

FIG. 45

doup ends on each pick of Fig. 45, it will be seen that two sets of doup harnesses will be sufficient to weave this design, since these are the only two sets of doup ends that work differently.

Having determined the number of doup and standard harnesses, next learn in the same manner the number of ground harnesses required. When each doup end crosses only 1 ground end, as is the case in this figure, there will be the same number of ground harnesses as there are doup harnesses. The number of back harnesses will, of course, be the same as the number of doup harnesses in every case, with the exception of weaves made on the principle of that shown in Fig. 41. The ends so far considered will require 2 doup, 2 standard, 2 back, and 2 ground harnesses, making eight levers of the dobbie that will be required for this part of the weave.

The first 24 ends of Fig. 45 can be placed on 2 harnesses, since this is the plain weave. However, it would be better to draw them in on 4 harnesses, which method will be adopted. It also becomes necessary before making out the harness draft, to determine which ends are drawn through right-hand douns and which require left-hand douns. Referring to Fig. 45, the first, third, and fifth doup ends are drawn through right-hand douns, while the second, fourth, and sixth doup ends are drawn through left-hand douns. It is possible now to commence to make the harness draft, shown in Fig. 46, the ends and the harnesses, through which they are to be drawn, being as follows: The first and second harnesses are the first doup and the first standard harnesses, through which the first, second, fifth, and sixth doup ends are drawn; the third and fourth harnesses are the second doup and the second standard harnesses, through which the third and fourth doup ends are drawn; the fifth, sixth, seventh, and eighth harnesses have the ends working plain drawn through them; the ninth harness is a ground harness, through which the first, second, fifth, and sixth ground ends are drawn; the tenth harness is a back harness, through which the first, second, fifth, and sixth doup ends are drawn; the eleventh harness is

a ground harness, through which the third and fourth ground ends are drawn; the twelfth harness is a back harness. through which the third and fourth doup ends are drawn.

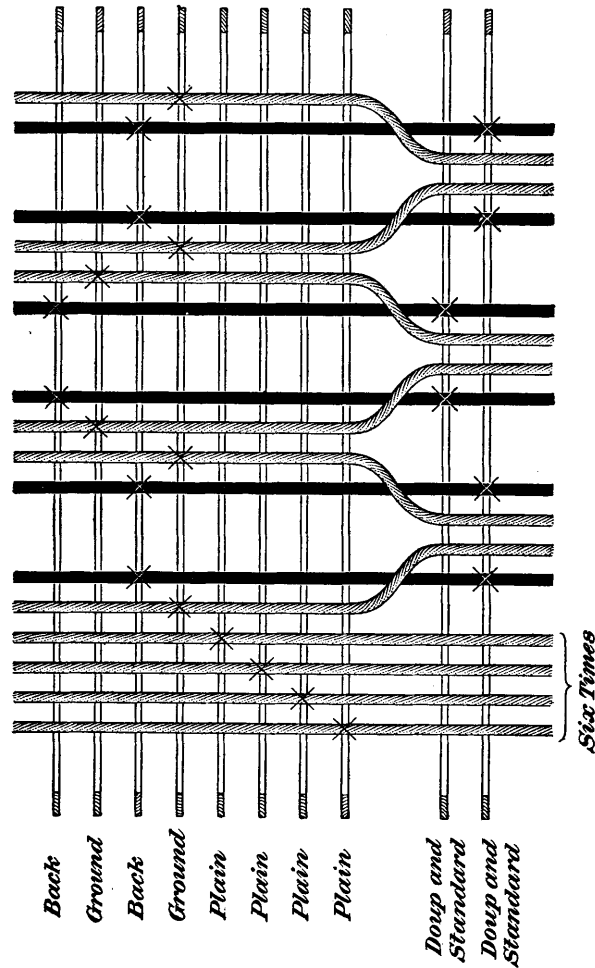

FIG. 46

49. As it is always necessary to have as many slackeners as there are sets of doup and standard harnesses, two slackeners will be required in this case, which will necessitate using two more levers of the dobby, making fourteen

altogether. When a gauze weave is combined with some other, such as plain, as in Fig. 45, it is customary to have at least a slight space between the front harnesses that carry the doup ends and the harnesses through which the ends forming the other weave are drawn. It will be assumed that with this weave two levers are omitted between those operating the two sets of doup and standard harnesses, and those operating the harnesses carrying the ends that work plain. The harnesses and dobby levers will therefore be connected in the following manner: First lever operates first doup harness; second lever operates first standard harness; third lever operates second doup harness; fourth lever operates second standard harness; fifth lever skip; sixth lever skip; seventh lever operates first plain harness; eighth lever operates second plain harness; ninth lever operates third plain harness; tenth lever operates fourth plain harness; eleventh lever, also jumper, operate first ground harness; twelfth lever operates first back harness; thirteenth lever, also jumper, operate second ground harness; fourteenth lever operates second back harness; fifteenth lever operates slackener for first set of doups; sixteenth lever operates slackener for second set of doups. The first and second and third and fourth levers are, of course, connected with yokes. Thus, with the harnesses arranged in this manner, a dobby with a capacity of at least sixteen levers will be required to weave the cloth, although, by not skipping any levers and by drawing the plain ends on 2 harnesses, it would be possible to reduce this number to twelve.

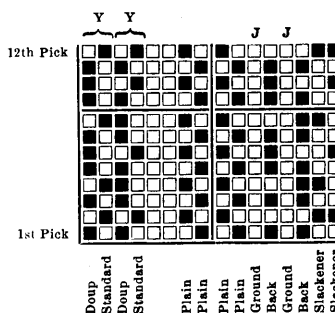

FIG. 47

50. Fig. 47 shows the chain draft for the weave Fig. 45 with the ends drawn in as shown in Fig. 46; by following each pick of Fig. 47 it should be readily seen how the effect

is obtained. On the first pick the following harnesses are raised: second plain harness, fourth plain harness, first doup, second doup, first back harness, second back harness. Consequently, all the doup ends are raised over the filling but do not doup; also, all the ends drawn through the second and fourth plain harnesses are raised over the filling. On the second pick the following harnesses are raised: first plain harness, third plain harness, first standard, second standard, both slackeners. This causes all the doup ends to cross, and brings up the ends drawn through the first and third plain harnesses. Following each pick through in this manner, it will be seen that in each case the effect shown in Fig. 45 will be obtained.

EFFECTS OBTAINED WITHOUT THE USE OF
ADDITIONAL MECHANISMS

51. Many good leno effects are obtained on open-shed looms without the use of additional mechanisms for causing

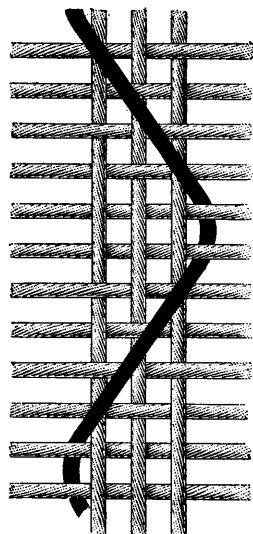

FIG. 48

the doup and ground ends to meet in the center of the shed by having the doup end both over and under the picks, but never interlacing with successive picks on opposite sides of the ground end, or ends, with which it works; that is, at least 1 pick is inserted between the picks on which the doup end interlaces on opposite sides of its ground end, or ends. It is evident that such weaves can be woven with top douns; therefore, since top douns are more convenient, and as they weave the cloth face up in the loom, they are often employed in preference to bottom douns in producing the leno effects described. Fig. 48 shows a weave of this type, the doup end being under some of the picks and over the other picks. Suppose that top douns are used; then on the first 2 picks the doup end is

carried down on the left of the ground ends; on the next 4 picks the doup end is up; but on the next 2 picks it is carried down on the right of the ground ends. If left-hand doups are used, the douping will take place on these 2 picks, but since the doup end has been up for the previous 4 picks, there is no necessity for any additional attachments to cause the doup and ground ends to meet in the center of the shed in order to produce the douping; that is, since the doup end is up on the previous pick, it is perfectly evident that the doup end is in such a position as to enable it to meet and cross the ground ends without any additional movement being imparted to it, whereas if it were down on the previous pick, it would have to be so

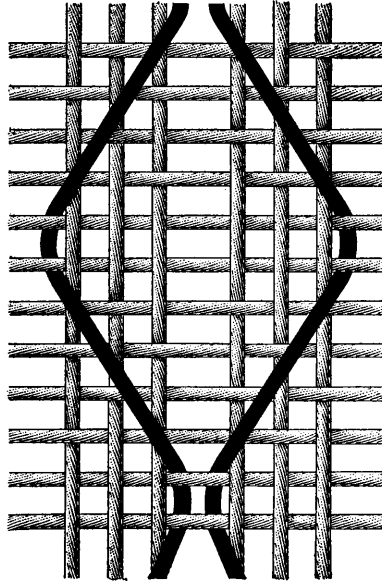

FIG. 49

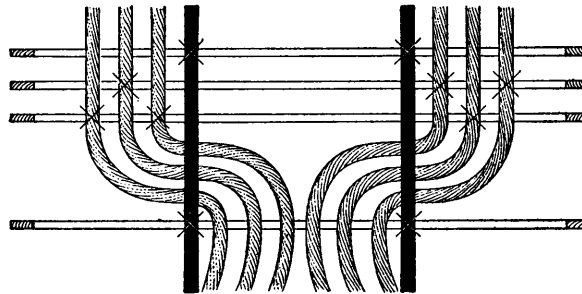

FIG. 50

operated as to meet and cross the ground ends before the insertion of this pick, which would necessitate the use of additional mechanisms. Weaves of this character are not

strictly leno weaves, but the effects produced are in many cases very similar to lenos.

The appearance of a cloth with a weave similar to that shown in Fig. 48 is greatly improved by using both right-hand and left-hand doups, which give a diamond effect, as shown in Fig. 49. The drawing-in draft for the weave shown in Fig. 49 when using top doups is shown in Fig. 50; Fig. 51 shows the chain draft.

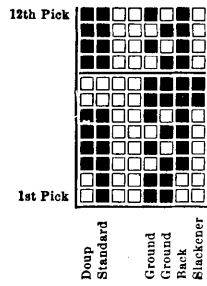

FIG. 51

Plain, twill, satin or other weaves may be introduced between the doup ends, as shown in Fig. 52. The drawing-in draft with top doups is shown in Fig. 53, and the chain draft in Fig. 54. In Fig. 53 it is indicated that the ground ends are to be drawn 2 ends per eye. This

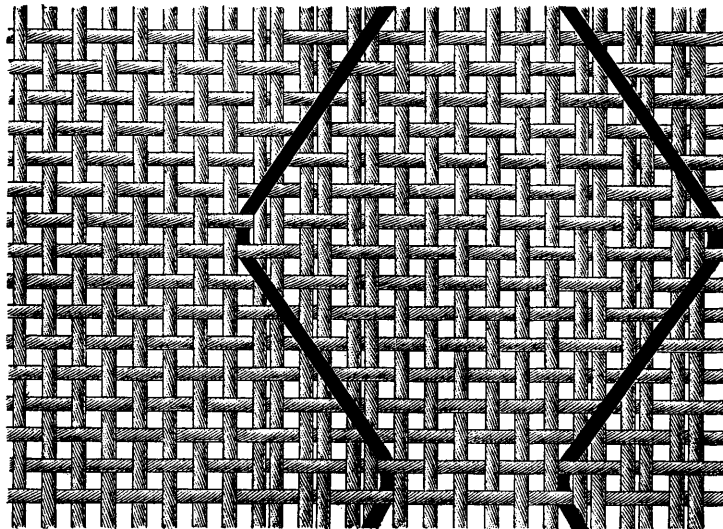

FIG. 52

means that each of the 3 ground ends, shown crossed by 1 doup end, represents 2 ends, which as shown in Fig. 52 work exactly alike. These 2 ends are drawn through the

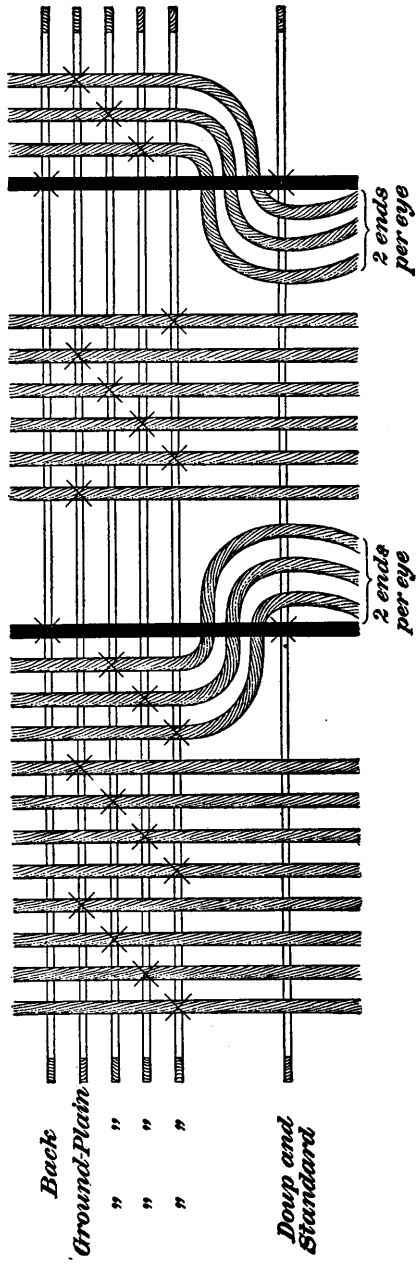

FIG. 58

harnesses as one end, and therefore, although in Fig. 53 only 3 ground ends are shown, each doup end virtually crosses 6 ground ends.

EFFECTS PRODUCED INDEPENDENTLY OF THE WEAVE

52. There are several ways in which the peculiar effects of leno weaving may be emphasized so that the design produced by any leno weave may be made more prominent without changing the weave itself. One of these methods is to use colored yarns for some of the ends, which may be either the doup or the ground ends. When this method is adopted, the best effect is usually obtained by making the doup ends the colored ends.

Different-sized yarns are also used to heighten the leno

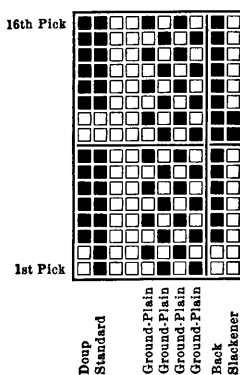

FIG. 54

effects, in which case they may be either ground or doup ends. If the ground ends are heavier than the doup ends with which they work they will force the doup ends farther from a straight line, thus increasing the zigzag effect. If the doup ends are heavier than their respective ground ends, they will show more prominently as ends, but they will not show as much deviation from the other warp threads. The heavy ends may be either single yarn of coarse counts or ply yarn composed of two or more strands of single yarn twisted together. An effect similar to that obtained by using heavy ends is produced by drawing 2 ends as one for either doup or ground ends.

53. Another important matter affecting the prominence of the leno effects is the regulation of the tension of the beams. In leno weaving the same precaution must be taken as in ordinary fancy weaving; namely, ends that vary considerably from other ends in take-up must be placed on separate beams. It will usually be found that only one beam is required when weaving plain gauze, though two

beams are sometimes used so that the tension of the doup ends may be regulated as desired; in weaving fancy gauze, however, several beams are usually required.

In a fancy-gauze fabric the take-up of the ends that weave in the ordinary way is determined by their interlacings. The take-up of the doup ends, however, is dependent not only on their interlacings, or the number of times they cross their respective ground ends, but also on the number of ground ends crossed; the greater the number of ends crossed, the greater will be the take-up of the doup ends. When more than one beam is used, it is customary to place the largest beam in the usual position in stands on the frame of the loom. The other beams are placed in a vertical row above this beam with the smallest beam at the top, the ends resting in adjustable stands placed on rods attached to the back part of the loom. This arrangement of the beams according to their size is adopted because a heavy beam, if placed above the loom, is liable to break some part of its comparatively weak supports, and in falling to break the loom or injure any one who is near it.

When doup ends are placed on a beam that occupies a position in the loom above the slackener rod, they are drawn and operated as already described, except that they are passed under the slackener rod. This general method is varied to a considerable extent in adapting it to peculiar conditions under which leno fabrics are often woven.

The result generally sought in leno weaves is the largest possible deviation of the doup ends from the straight line taken by the other ends, and this is accomplished by putting considerable tension on the beam carrying the ground ends and by placing little tension on the beam containing the doup ends, so that the ground ends tend to retain their position and force the doup ends to make a sharp angle with the other ends. The proper regulation of the proportionate tension of the different beams, though apparently a simple matter, contributes very largely to the effectiveness of any leno weave.

DISSECTING LENO WEAVES

54. When seeking to pick out a leno weave and to find all the particulars necessary for reproducing a cloth of this character, it should be understood that it is not possible to ascertain the weave, at least the gauze part of it, by picking out each pick separately and marking its interlacings on the design paper. The best plan to follow is to study the weave carefully with the aid of the pick glass, endeavoring to understand the method of interlacing that is employed, and after this has been learned, to mark out the chain draft on the design paper.

55. In a great many leno fabrics open spaces occur between the different sets of doup ends. This is caused by leaving a number of dents in the reed empty and having several ends drawn through other dents. The crossing of the ends that takes place in gauze weaving retains the ends in their proper positions when in the cloth, which would not be the case if any dents were left empty when weaving an ordinary fabric.

In cases where a doup end crosses several ground ends that work plain part of the time, as in the weave shown in Fig. 32, the splits, or wires, of the reed that would naturally separate the ground ends must be taken out, in order to allow the doup ends to cross them in weaving; this also leaves sufficient space for the ends to spread when weaving plain instead of gauze.

56. The doups that pass through the heddles of the standard harness are fastened securely to the framework of the doup harness, generally by being sewn to a cord fastened to the frame; consequently, they can be placed in the exact position that they should occupy. It is necessary, however, to give definite instructions to the person doing this work, since, if the doups are not made to occupy a position that will bring them in direct line with the ends drawn through them, considerable chafing of both yarn and doups must necessarily follow.

It is the custom when giving particulars for the doup harness, to state exactly how much space exists between the gauze stripes, and how much space each stripe occupies, together with the number of doups necessary for that stripe. For example, 4 doup ends may be working together to form a stripe, occupying $\frac{1}{4}$ inch; then the four doups necessary for these ends will be distributed evenly on $\frac{1}{4}$ inch of the doup-harness frame. Next, there may be 1 inch of plain cloth in which no doup ends appear; consequently, this space will be skipped, then four more doups fastened to the frame, and so on until the whole is completed. In this way the harness maker will leave spaces on the harnesses to correspond with the requirements of the design. In cases where part of the doups are right-hand and part left-hand, the necessary instruction for this part of the work must also be given, so that the desired effect will be produced. A convenient method employed in preparing the doup harness is to mark off on a stick the positions of the doups throughout the width of the warp, the stick being then used as a guide in fastening the doups to the doup harness.