

**WEAVING WITH
SMALL APPLIANCES**

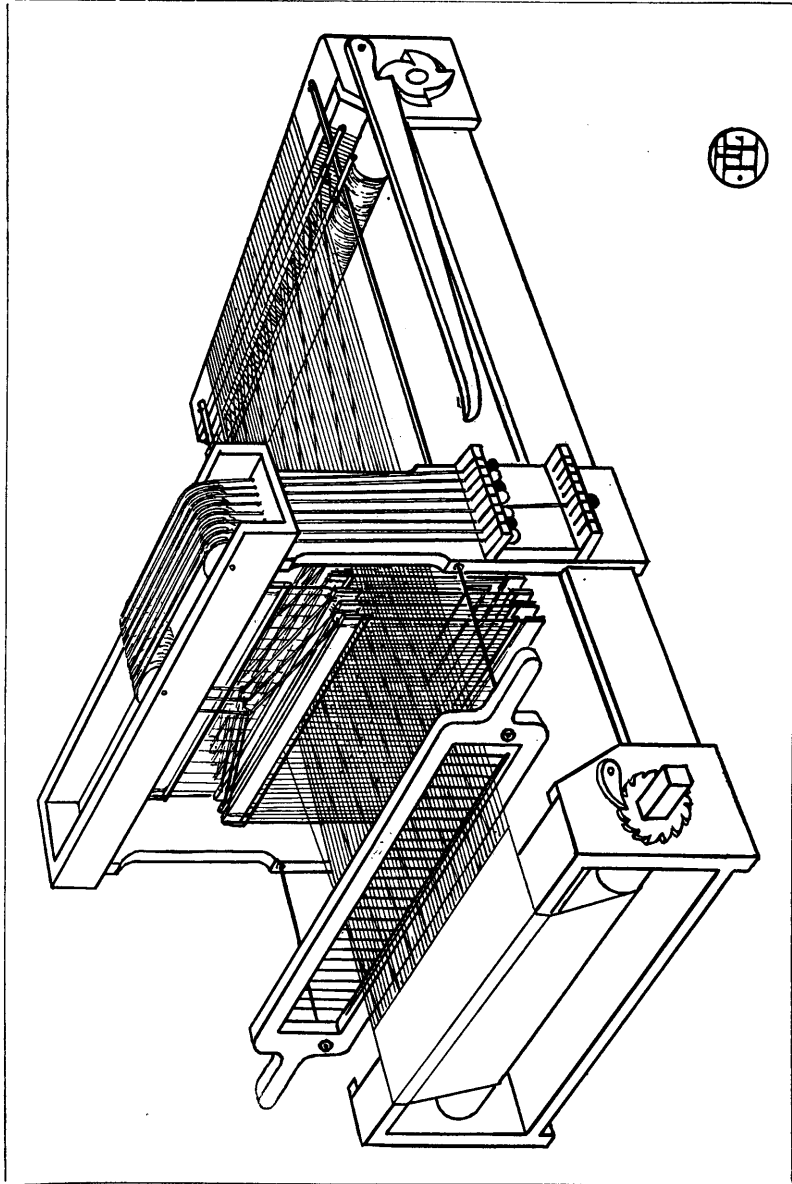

Fronispiece

WEAVING
WITH SMALL
APPLIANCES
WRITTEN & ILLUSTRATED

BY

LUTHER HOOPER

DESIGNER AND WEAVING EXPERT; AUTHOR OF "HAND-
LOOM WEAVING, PLAIN AND ORNAMENTAL"; "SILK";
"THE LOOM AND SPINDLE"; "WEAVING FOR
BEGINNERS," ETC.; LATE LECTURER IN AND TEACHER
OF WEAVING AT THE LONDON COUNTY COUNCIL CENTRAL
SCHOOL OF ARTS AND CRAFTS, [SOUTHAMPTON ROW,
LONDON

BOOK III — THE TABLE LOOM

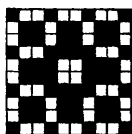

LONDON

SIR ISAAC PITMAN & SONS, LTD.
PARKER STREET, KINGSWAY, W.C.2
BATH, MELBOURNE, TORONTO, NEW YORK

1925

WEAVING WITH SMALL APPLIANCES SERIES

By LUTHER HOOPER

Each in foolscap 4to, with coloured and
black-and-white illustrations. 7s. 6d. net.

I. THE WEAVING BOARD

The appliances for weaving, and the
instructions for using them, which are
described in this book are specially designed
for and adapted to the use of students.

II. TABLET WEAVING

Many kinds of beautiful braids and laces
can be woven by this simple method.

III. TABLE-LOOM WEAVING

LONDON: SIR ISAAC PITMAN & SONS, LTD.

CONTENTS

CHAP.	PAGE
I. THE TABLE LOOM DESCRIBED	I
II. THE PARTS OF THE LOOM AND THEIR USES	3
III. SETTING UP THE LOOM FOR WORK	9
IV. MAKING, TURNING ON, AND ENTERING THE WARP	16
V. REGULATING OR GATING THE LOOM	25
VI. GETTING TO WORK	26
VII. THE POSSIBILITIES OF VARIETY IN TEXTURE AND PATTERN ON THE TWO-HEADLE LOOM	28
VIII. ORNAMENTAL WEAVING ON THE MULTI-HEADLE TABLE LOOM	31
IX. FLUSHING, THE BASIS OF ALL ORNAMENTAL WEAVING	35
X. TWILLING ON FOUR HEADLES	37
XI. BROKEN TWILLS	41
XII. DESIGNS ON EIGHT HEADLES	43
XIII. BIRD-EYE DESIGNS ON FOUR OR EIGHT HEADLES	49
XIV. TURNED OR REVERSED TWILLS: THEIR VALUE AND CONSTRUCTION	56
XV. COMPOUND PATTERN WEAVING	60
INDEX	71

ILLUSTRATIONS

FIG.		PAGE
	Table with Eight Headles	<i>Frontispiece</i>
1.	Frame of Table Loom	4
2.	Headle Frame for Two-roller Headles	5
3.	Headle Frame for Pattern Weaving	6
4.	Headle Frame and Reed Holder in Position	8
5.	Cording of Headle Frame (1)	10
6.	Cording of Headle Frame (2)	11
7.	Preparation for Entering	12
8.	Cording of Headle Frame (3)	13
9.	Turning on the Warp (1)	17
10.	Turning on the Warp (2)	18
11.	Turning on the Warp (3)	18
12.	Turning on the Warp (4)	19
13.	The Beaming Drum	20
14.	The Side Cords for Entering	21
15.	Preparation for Entering	22
16.	Preparation for Entering	23
17.	Plan of Entering of Four or Eight Headles	24
18.	Plan of Diamond Entering	31
19.	Effects of Diamond Entering	32
20-21.	Effects of Different Enterings	34
22.	Twilling on Three, Six, and Eight Headles	37

FIG		PAGE
23.	Plan of Entering a Four-headle Twill	38
24.	Plans of Entering a Four-headle Wave and a Broken Twill	39
25.	Variants of Regular Twills	40
26.	Plans of Broken Twills	41
27.	Eight-headle Twills	43
28.	Plans of Eight-headle Twills	44
29.	Cording for Eight-headle Satin	45
30-32.	Plans for Fancy Twills	47-48
33.	Bird-eye Patterns	49
34.	Plans for Bird-eye Patterns	50-51
35.	Method of Weaving Tabby with Bird-eye Entering	52
36.	Plan for Bird-eye Pattern of Four Headles	52
37.	Designs on Bird-eye Entering	53
38.	Plans of Fig. 37	54
39.	Example of Reversed Twill	56
40-43.	Examples of Reversed Twills	57-58
44.	Entering of a Compound Harness	61
45.	Diagram of a Point Repeat	62
46.	Design for Compound Harness Weaving	64
47.	Plan of Cording for Fig. 46	65
48.	Effect of Compound Harness	67
49.	Design for Compound Harness Weaving	69

COLOURED PLATES

PLATE	FACING PAGE
I. Brocaded Plain Tabby Web	I
II. African Tabby Web with Striped Warp and Weft, and Primitive Brocading.	29
III. Designs for Four-headle Harness	38
IV. Designs for Fancy Stripes	47
V. Designs for Bird-eye Patterns	50
VI. Samples of Various Woven Designs	53
VII. Reversed Satin or Diaper Weaving	58
VIII. Compound Harness Weaving with Weft Binder	68

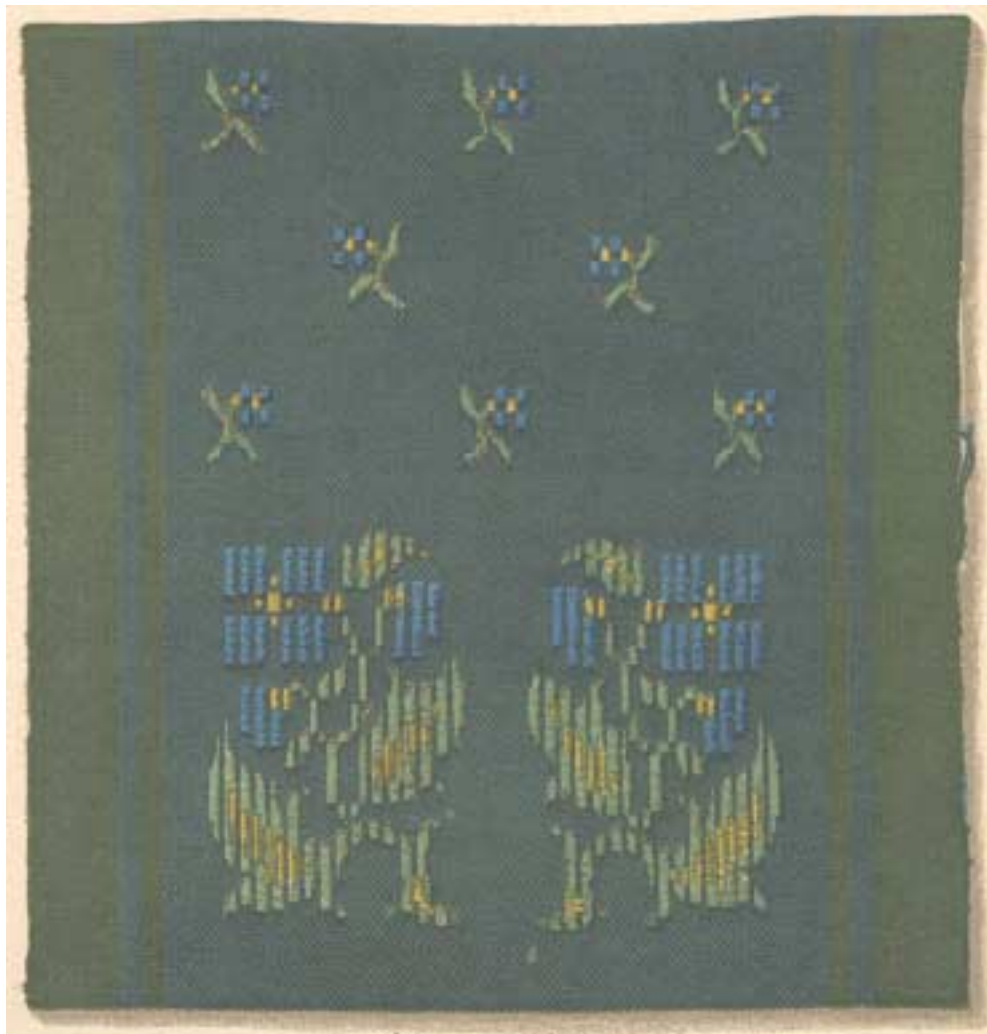

THE TABLE LOOM

CHAPTER I

THE TABLE LOOM

THE table loom, a drawing of which forms the frontispiece illustration of this, the third part of WEAVING WITH SMALL APPLIANCES, has been carefully planned by the author so as to be adapted not only for weaving plain fabrics for domestic use, where only a small space can be afforded for the process, but, with the addition of certain simple fittings, to furnish the student of ornamental weaving with a loom on which a very great range of designs can be worked out with the least amount of tedious alteration of the mounting and mechanism. This handy loom should also prove useful to the designer, in any weaving workshop, for making samples for approval as well as experiments in new interlacements and combinations of threads, to which the experienced weaver must have realized there is absolutely no limit.

The simplest form of table loom can be mounted for weaving materials 16, 20, 24, 32, or 40 threads of warp to an inch according to the count of reed made use of. The warp, in this loom, is entered on two headles mounted on rollers which are actuated for opening the shed, through which the shuttle is passed, by a convenient handle

placed at the right-hand side of the loom. This handle takes the place of the treadles of the ordinary loom.

The table loom, for automatic pattern weaving, is mounted with a system of pulleys and cords, the latter terminating in a rack and bead in such a manner that one or more of the headles may be raised at will in the same manner as was possible on the ancient *draw loom* and its successor the Jacquard weaving appliance. The number of headles on this loom may number 4, 8, 10, 12, 16, or even 20, so that quite extensive designs may be arranged to work out on it, especially when it is entered for compound weaving.

Each kind of loom is made in two sizes, viz. : to make material up to 18 or 21 inches wide.

A description of the essential parts of the loom, the method of fitting it up, the appliances for preparing the warps and entering them in the loom and setting to work, as well as typical designs and specifications will all be contained in the following chapters. It will be necessary however, in order to limit this part of the book to its allotted proportion of space, to make the description of the parts of the loom which are common to all looms very brief, in order that the greatest possible number of designs, examples and specifications for plain and ornamental webs may be furnished to the student. It may therefore be necessary for the reader sometimes to refer, for the description and explanation of certain details, to the Author's former works, *Hand-Loom Weaving, Plain and Ornamental*, and *Weaving for Beginners*.¹

¹ *Weaving for Beginners*, 5s., and *Hand-Loom Weaving, Plain and Ornamental*, 10s. 6d., both published by Sir Isaac Pitman & Sons, London.

CHAPTER II

THE PARTS OF THE LOOM AND THEIR USES

As will be seen in the frontispiece, the framework of the table loom is designed for strength and solidity. These are indispensable qualities in all kinds of looms which have any pretensions to utility. The frame itself consists of four parts, viz. : two ends, each of which is fitted with a roller, one for the front and one for the back of the loom, and two side pieces which are firmly bolted to the ends and have to bear the strain of the warp, which is stretched between them at a great tension, from one roller to the other. The only difference between the front and back ends of the loom frame is in the rollers ; that at the front has a ratchet wheel at one end of it having very small teeth, whilst the roller at the opposite end has a ratchet wheel with very large teeth : also that the teeth themselves are placed in opposite directions, so that when the catches of the ratchets are in position as shown in the drawing and in Fig. 1, the rollers can only be turned in opposite directions away from each other and will remain fixed, when the warp is attached to them, and hold the latter at any tension which may be desired by the weaver. In Fig. 1, A is the front of the loom, B the back, and the line C is the warp stretched between the two rollers.

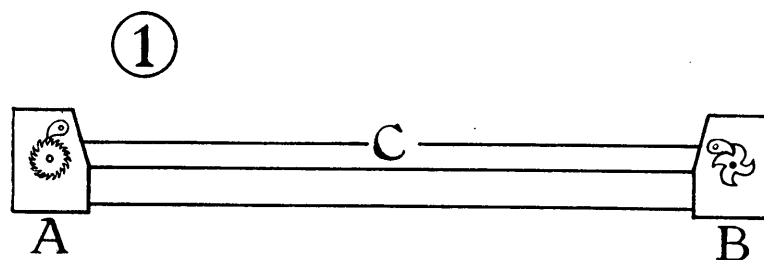

The next part of the loom to claim attention is the *Harness holder* which is firmly bolted to the sides of the frame rather nearer to the front roller than to the back one. Beneath the cross-pieces at the top of the holder the *headles* of the harness are suspended, either from a roller governed by a handle or from a set of pulleys as already mentioned and shown in the frontispiece which is drawn from a table loom *fully mounted for ornamental weaving*.

The *shedding motion*, as the more or less complicated fittings for opening the shed are technically called, of the two looms will be best described with the help of the two diagrams, Figs. 2 and 3.

The shedding motion (Fig. 2) for the plain weaving loom, is quite simple and consists only of a pair of rollers fixed one above the other. There is a handle at one end of the top roller by means of which it can be turned half round, backward or forward, as the weaver desires. Only two headles are required for warps up to forty threads to the inch and under, and they are so fixed to the rollers that when the handle, connected with the top rollers, is turned half round one headle is raised and the other depressed. The result of this is that an open shed is formed between all the odd and even threads of the

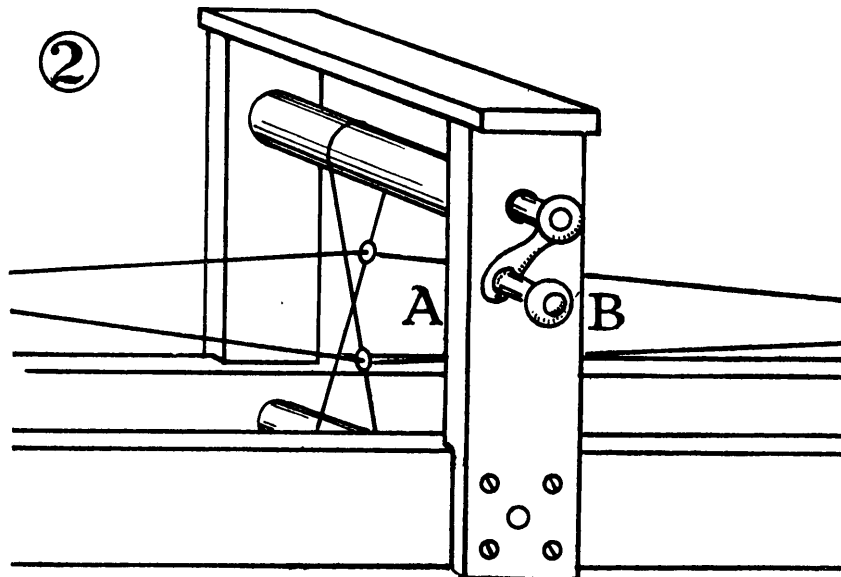

warp. For example, when the handle is in the position shown at A, Fig. 2, the odd numbered threads of warp Nos. 1, 3, 5, 7, etc., will be near the top of the reed, and the even Nos. 2, 4, 6, 8, etc., will be at the bottom, thus opening the first shed. If the handle be then turned half round to letter B the even threads will come to the top and the odd threads sink to the bottom ; the second shed will thus be opened.

The pulley motion for ornamental weaving, Fig. 3, is rather more complicated, as might be expected. It can be adapted to control as many as twenty headles and, if special enterings of the warp threads are made use of and the compound principle of weaving is arranged for, quite extensive designs can be readily woven on the table loom to which it is attached.

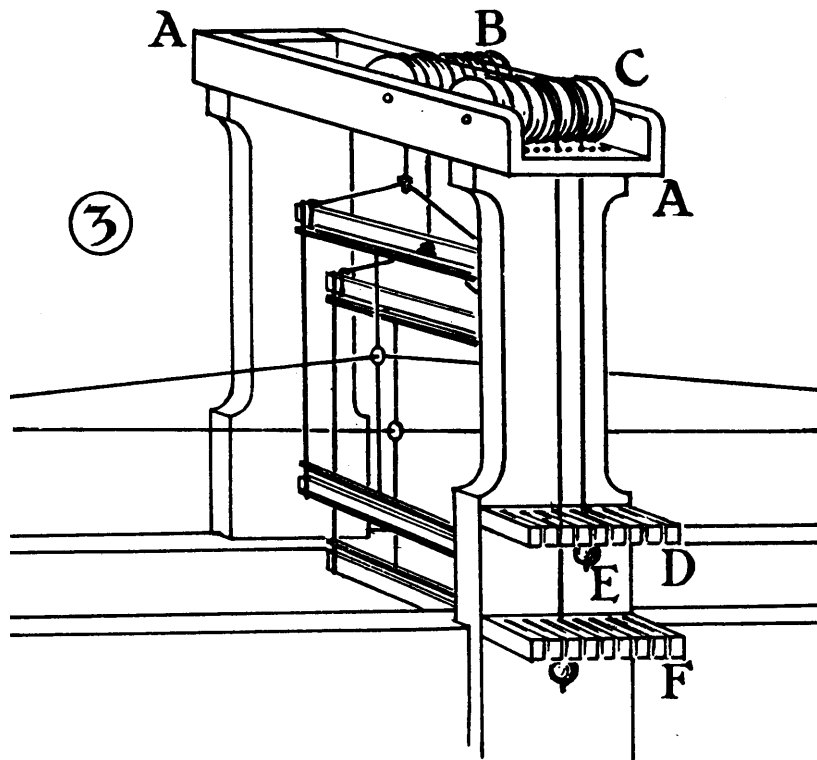

The diagram, Fig. 3, represents a pulley mounting for a harness of eight headles, and a careful study of it will make clear the method of its working and demonstrate its great utility in ornamental weaving. It enables the weaver to have perfect command of any one of the headles or any combination of them. The designs on Plates III, IV, and V are only a few of the vast number of patterns possible on such a mounting. The method of working out these designs will be given later, but just

here the mounting itself must be described. In this case the top of the harness holder is a strong frame in which two rows of eight pulleys each are fixed, one row at the centre B B, and the other at the end C C. Over these pulleys run the cords from which the eight headles of the harness are hung, as shown in the frontispiece. In Fig. 3, however, for the sake of clearness, only two headles are shown fitted up, and from these it will be seen that the cords on which they hang pass over a pulley at B, then over a pulley at C, and, after passing through a hole in the rack, terminate with two large beads at E and F. When the loom is at rest all the headles are in the position of the one with the bead at E. In order to make a shed for weaving one or more of the headles must, of course, be raised. This is effected as follows: four inches below the rack D there is another rack F. This rack is notched, one notch beneath each bead; now it is obvious that if the bead E be pulled down and fixed below the first notch F, the headle at the other end of the cord will be raised. In the drawing the front headle is shown thus raised. The eight headles, cords and beads being all fitted up in the same way, any headle, or combination of headles, necessary to form one line of a design can be raised by *selecting and pulling down the bead or beads corresponding to it.*

In the table loom, the reed for beating the weft together is fixed in a holder which works in such a manner that every time it is pulled forward the blow falls horizontally on each line of weft left in the shed by the shuttle. This direct pressure is a great advantage, especially in a small loom. Fig. 4 is a side elevation of the loom which will explain the mechanism of the reed holder. A, Fig. 4,

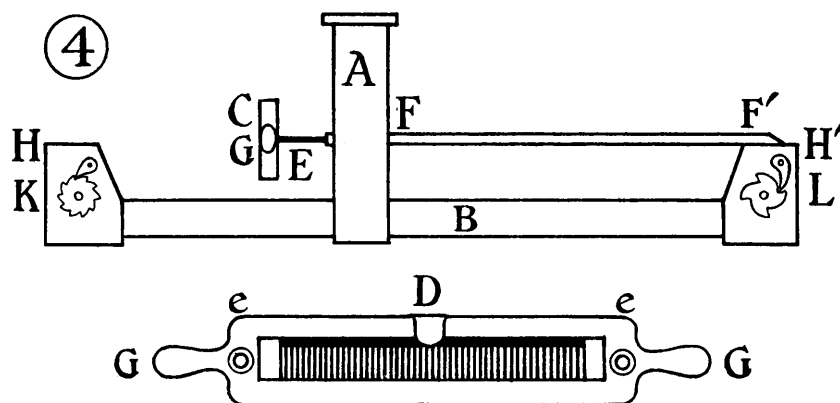

is the headle frame fixed on the side of the loom frame B. C is the end of the reed holder, the front view of which is given at D. A stout iron rod is screwed into each end of the reed holder, D, at the places marked e, e, and is shown in position at E in the side elevation, Fig. 4. F F' is a tube of metal which is passed through a hole in the side of the headle holder and is firmly fixed to the end of the loom, above the back roller as at F'. There is one such tube at each side of the loom and into these tubes the two rods, attached to the reed holder, run just easily enough to allow the reed to be brought forward by means of the handles (G, G, and G, Fig. 4) and pressed with some force against the weft as it is gradually added line by line to the web. The advantage of the weft beater over the ordinary batton or sleigh will be explained later on.

CHAPTER III

SETTING UP THE LOOM FOR WORK

EXCEPT for a few special points peculiar to the table loom, in which it differs from the ordinary treadle loom, the description of winding, warping, *beaming* or warp spreading, *entering* or threading and starting to weave, contained in the first book of this series, *Weaving for Beginners*, and the author's larger book, *Hand-Loom Weaving*, will apply perfectly to the preparation and setting up of the table loom for work. As, therefore, it is desirable that all the space possible in the present part of *Weaving with Small Appliances* should be devoted to examples, designs and specifications for different textures and ornamental fabrics, the student is referred to these earlier books for exact information and details of these necessary preparatory processes.

The table loom, if supplied in parts for convenience of transit, will first have to be fitted together. The four parts of the frame, the ends with the rollers, and the sides must be bolted together and fastened by means of the wing nuts on the bolts. Next the headle frame, Fig. 2 or 3, must be placed in position as in Fig. 4, A, and firmly bolted to the sides of the frame. In the case of the cross headle loom (Fig. 2) for plain weaving all is now ready to receive the warp, but in the ornamental weaving loom (Fig. 3) the headle frames must be strung and fixed in their position in the headle holder. The

stringing and mounting of the headle frames must be done very carefully and accurately in order that the warp when at rest may lie perfectly flat and horizontal between the front and back edges of the frame H H, over which it passes from the warp roller I to the cloth roller K (Fig. 4).

Fig. 5 illustrates the method of stringing the headles and Fig. 6 shows the cording by which they are hung from the pulleys and connected with the beads below

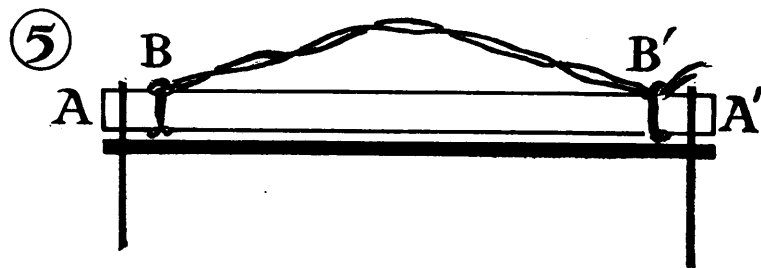

the pattern rack at the side of the headle frame D, Fig. 3.

A A', Fig. 5, shows the top lath of a headle frame having a double cord securely tied to it. It is prevented from slipping along the lath by two notches made in the top of the lath at B B'. The cords on all the headles must, of course, be exactly the same length, their length being just sufficient to draw the cords when they are all looped to the pulley cord, at such an angle as shown by Fig. 6 between B and B'.

The simplest way of stringing the headles is as follows. Take a cord about three times as long as the space on the lath between the two notches B and B', Fig. 6, and after doubling it, place the cord at its exact centre across

the lath in the notch B, Fig. 6. Next pass the two ends of the cord in *opposite directions under* the lath, bring them up on each side of it and tie a double knot very tightly over the cord in the notch. One end of the double cord being thus firmly fixed, the two separate strings must be joined together about four inches from the ends by a simple knot. This knot must be placed in the

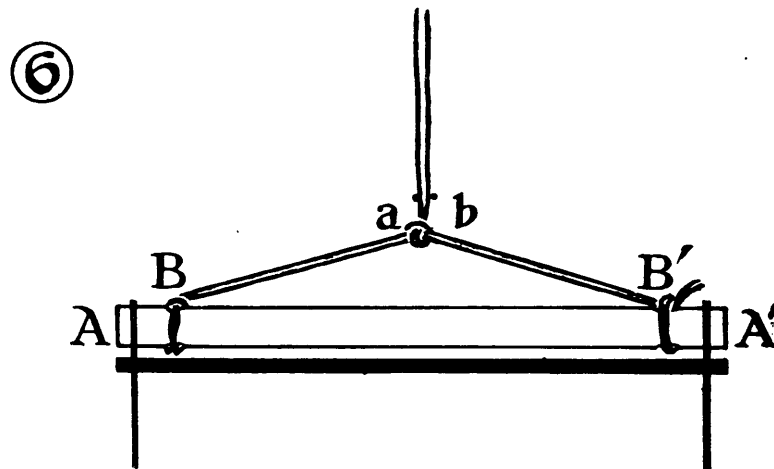

notch B' which remains empty, and the two loose ends passed under, brought up and tied over the knot in the notch in the same way as the knot in the notch at B, Fig. 6. In tying the cords to the lath great care must be taken to stretch them round it and to tie the double knots very firmly so as to prevent the cords from slipping along the lath when the weight is on and the harness is in constant use.

Before the headles can be attached to the pulleys, as shown in Fig. 3, they must be hung in their position in

the headle frame, on two temporary supports, at the exact height at which they will have to remain when the loom is at rest. These temporary supports are merely short, flat laths, the ends of which are seen at D D, Fig. 7, and they are placed underneath the top laths of

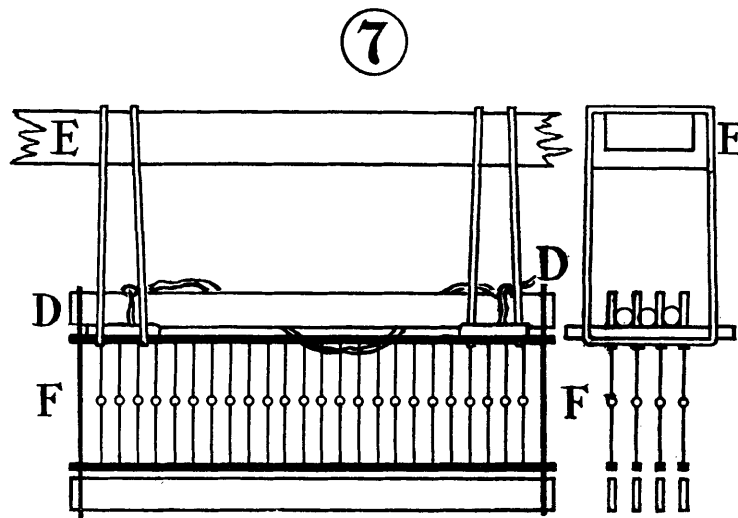

the headles, near the ends, and are slung by a cord to the headle frame E E, as in the drawing.

The height of the headles in the loom must be such that the eyes of the headles F F, Figs. 7 and 8, are exactly on a level with the front and back bars of the loom H and H', Fig. 4.

The headles being in position may now be connected with the rows of pulleys B C, and the bead rack D D, Fig. 3 and Fig. 8. The way in which this is to be done

will be readily understood by reference to the drawing, Fig. 8.

In the first place eight lengths of cord will be required long enough when doubled to reach from the top lath of

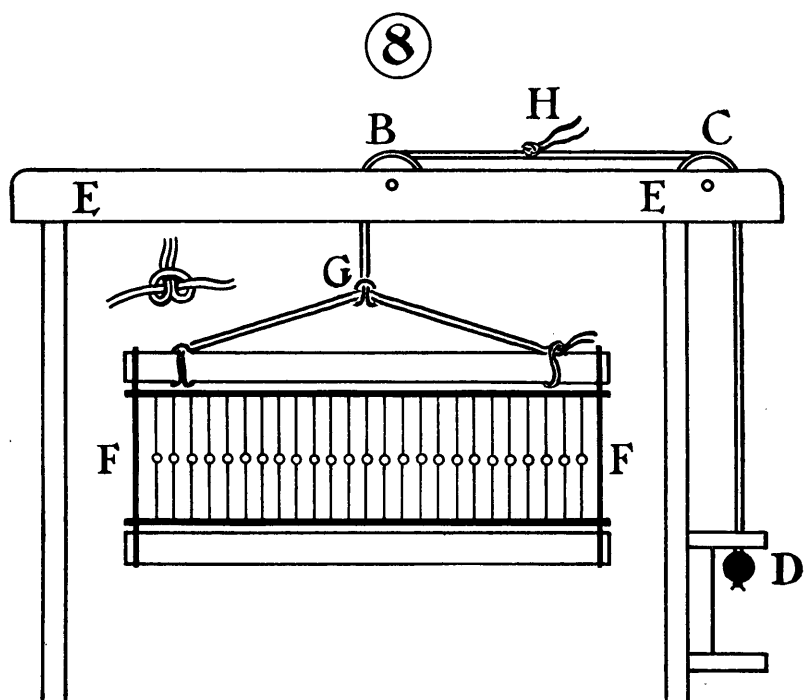

the headles to C, after passing over the pulley B. These cords are all to be attached to the double headle cords at G, Fig. 8, by a slip loop, shown to the left of G, before it has been drawn tight.¹ When these cords have been

¹ The method of making this loop and its great utility in loom harness construction are fully described in *Weaving for Beginners*, page 2.

attached to the headle cords another set of eight cords will be required to connect them with the beads in the rack D. These cords must be long enough, when doubled, to reach from B over the pulley C to about 4 inches below D, Fig. 8.

When these lengths are ready, one length must be taken and doubled and a slip loop must be made through which the two ends of the cord from the first headle can be passed after going over the first pulley at B. The loop must be drawn tight and the two ends of the headle cord tied together in a single knot : this junction must be made half-way between B and C. The loop knot being drawn close and firm, the double cord must be carried over the pulley C, through the hole in the headle frame, corresponding with the groove in the pulley, down to the bead rack D, threaded through the bead and tied in a firm knot so as to fix the bead in its place. This will, of course, complete the connection between the *bead* in the rack and the *headle* in the frame. The loop and knot H are for the purpose of nicely regulating the length of the pulley cord at will. To shorten the cord it is only necessary to draw the ends of the pulley cord through the loop of the bead cord and tighten the single knot, while to lengthen the cord the knot must be loosened and slightly moved before drawing it tight again. When the warp is entered in the headles and the slings D D (Fig. 7) are removed, the headle cords will, of course, require nicely adjusting, by means of this slip knot, so as to make them hang evenly and level.

As mentioned on page 7, a special feature of the table loom is the arrangement made for beating the weft

together with the reed. It is called the reed carrier and takes the place of the batton of the ordinary loom. In one respect in particular it is superior in its action to the ordinary swinging batton, whether the latter is hinged above or below the warp. The reason of its superiority is that its blow on the weft is directly *horizontal* during the progress of weaving, not *oblique* as is more or less the case when a hinged or swinging batton is used.

The horizontal movement of the reed holder in the table loom obviates the necessity of altering the position of the web by winding it on to the front roller so frequently as in the treadle loom with its swinging batton. When, however, the movement of the reed between the work and the headles becomes too restricted, all that is necessary is to raise the lever,¹ placed behind the headle frame which fixes the ratchet wheel, and so free the back roller as to allow the catch to pass over one or two teeth of the wheel: at the same time the front roller must be turned by means of the handle so as to wind the woven cloth on to the front roller. This must, of course, be done very carefully and in such a way as to allow the cloth to remain in its true position in relation to the reed and headles. After the back roller has been again fixed by the lever catch, the warp must be tightened up by means of the handle and the small toothed ratchet of the front roller.

The reed holder for the table loom is fixed by locknuts on two iron rods which fit into two metal tubes placed between the headle frame and the back bar of the loom as described on page 7 and illustrated by Fig. 4.

¹ The lever is shown in the drawing of the 8-headle loom in the frontispiece but not in Fig. 4.

CHAPTER IV
MAKING, TURNING ON AND ENTERING
THE WARP

AS mentioned in the last chapter the processes of warping, turning on and entering are so fully described in *Weaving for Beginners* and *Hand-Loom Weaving*, that in the present chapter it will only be necessary to deal with the special arrangements required for applying the instruction there given to the table loom, whether it be the simple two headle loom for plain weaving or the more complicated eight to twenty headle one for ornamental weaving. Chapter VI in *Weaving for Beginners*, if the warping board with pegs is used, should be studied at this point, but if a warping mill is available, which in many respects is far better than a board, Chapter IV in *Hand-Loom Weaving* should be carefully read and mastered.

The warp being ready, the arrangements to be made for turning it on to the back roller of the table loom must be next considered, as these differ slightly from those described for the ordinary loom.

First the loom must be firmly fixed by clamps or tied by ropes to a table top, in such a way as to leave the back roller clear to receive the rod having the end of the warp attached to it, in the manner presently to be shown.

The most convenient way of fixing the loom and its position on the table will best be described by the drawing,

Fig. 9, in which A A is a table or bench, the heavier and longer the better, and B B is the loom fixed by a strong iron clamp C to the edge at the end of the table top and exactly in the corner so that the handle of the roller D can be freely turned without coming in contact with the side edge of the table.

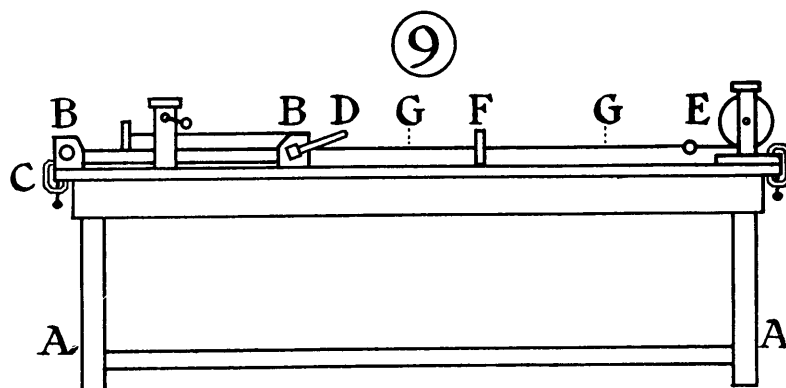

The loom being thus ready and the warp wound on the hand stick as described at the end of Chapter VI in *Weaving for Beginners*, Chapter VII in the same book must be read and its directions followed until page 49 is reached, from which point *turning on* for the table loom requires different directions.

If the handy appliance for beaming the warp shown at E, Fig. 9, which will be explained later on, is not used the work can be done, though less accurately and quickly, with the help of two assistants, one to manipulate the riddle F, Fig. 10, and one to stand at the end of the table and pull the warp as evenly and at as equal a tension as possible as it unwinds from the hand stick and is

wound on to the roller of the loom by the operator at the handle D.

The line G G, Fig. 10, is the warp spread out by means of the raddle which it passes through, as described at page 51 in *Weaving for Beginners*. The rod with the end

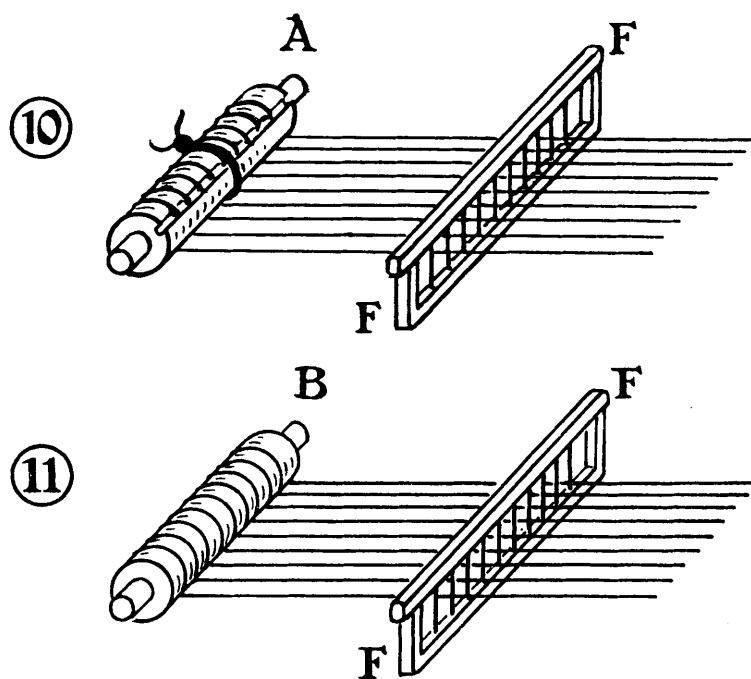

of the warp looped round it has, of course, been put into its groove in the centre of the roller at B, securely tied in and the roller turned *once* round so as to fix the rod safely in the groove before any strain or tension is given to the warp by the assistant. The fixing of the rod thus in the roller will be made clear by Figs. 10 and 11.

In Fig. 10 at A, the rod has been placed in the groove and tied in by a string round the centre of the roller. This string would, of course, be insufficient to hold the rod in place if any strain were put on the warp, but if the roller be turned once round, so as to enclose the rod with the warp, as at B, Fig. 11, the more tension given to the warp the more safely the rod will be held in its place.

A second assistant must hold the raddle F, and by moving it backward and forward clear the threads as they are wound on, and also very slightly move it

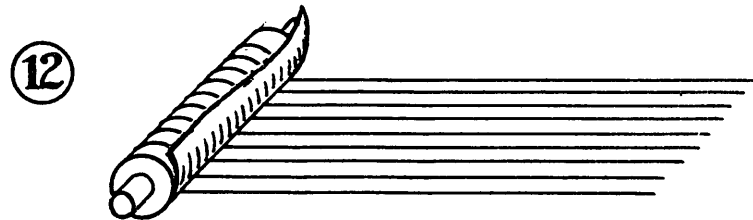

in the opposite direction so as to spread it evenly on the roller. Great care in this part of the operation is well repaid by the result of a smooth, even and solid warp which will give the weaver little trouble from loose and uneven threads coming up as the weaving of the web proceeds. A great deal also will depend on the assistant at the end of the table keeping a strong, equal tension on the warp as it is turned on.

If the warp is of any considerable length it is very helpful to insert every now and then a sheet of thick smooth paper across the warp as shown at Fig. 12. The paper must be a little wider than the space occupied by the warp.

The little appliance shown fixed at the opposite end of the table to the loom at E, Fig. 9, is a miniature beaming drum which enables the warp to be turned on at any degree of tension required and with perfect equality throughout its length. It also dispenses, of course, with the services of an assistant at the end of the warp to give it the necessary tension as described at page 17.

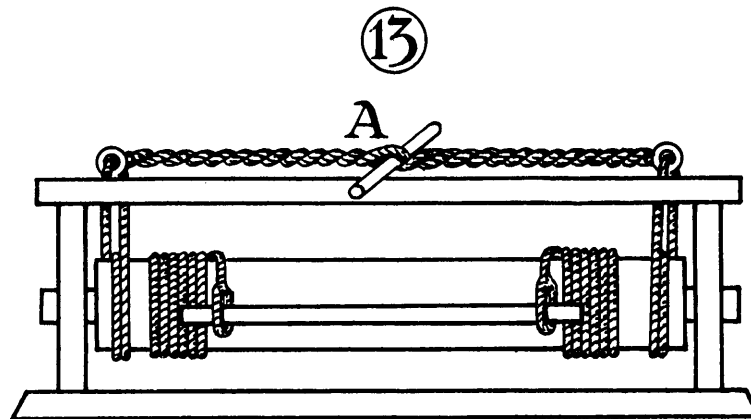

Fig. 13 is a representation of the small beaming drum suitable for use with the table loom. It is used in exactly the same way as the full sized drum described in *Hand-Loom Weaving* at page 73. If the description there given be well studied the student will have no difficulty in using the small drum shown clamped in the proper position for use at E, Fig. 9.

A comparison of Fig. 13 and the illustrations of the beaming drum in *Hand-Loom Weaving* will show that the only material difference between them is the method of regulating the weight of resistance to the turning on of

the warp. In the large drum the resistance is given by leather straps and weights, but in the small one the tension is regulated by a rope wound once round the roller at both ends and tightened in its grip by being twisted by means of a short, strong stick A, Fig. 13.

A full description of the general principles of entering the warp threads separately and in exact order in the headles and reed of a full sized loom is given in Chapter

①4

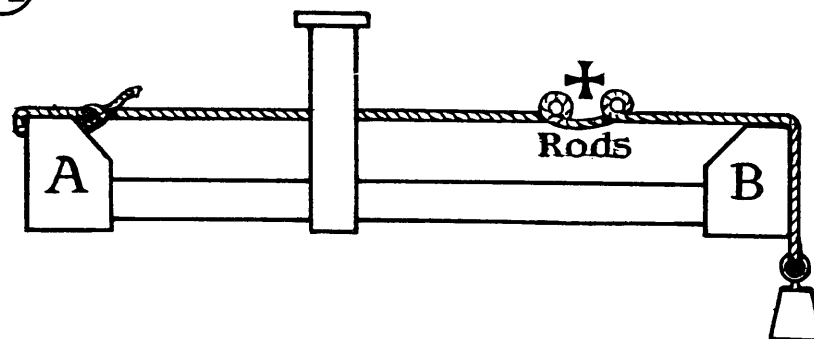

VIII of *Weaving for Beginners*. This description applies also, with two or three slight modifications, to the entering of the table loom: these differences are as follows: The side cords which support the two sticks which keep the cross in the warp must be attached to the front *bar* of the loom at A, Fig. 14, instead of to the *post*. The cords must also pass over the back bar at B instead of being passed round the back roller. Then again, there is no need for the notched supports for the headles, Fig. 33, *Weaving for Beginners*; the slings shown at Fig. 7, D D, page 12, will be sufficient to hold the

headles quite firmly if a little piece of rod is rested on the slings between each headle and the whole number of headles tied tightly together by a cord as shown in Fig. 15 in which A A is the sling, and between B and B B B are the headles fixed by the rods and cord. In

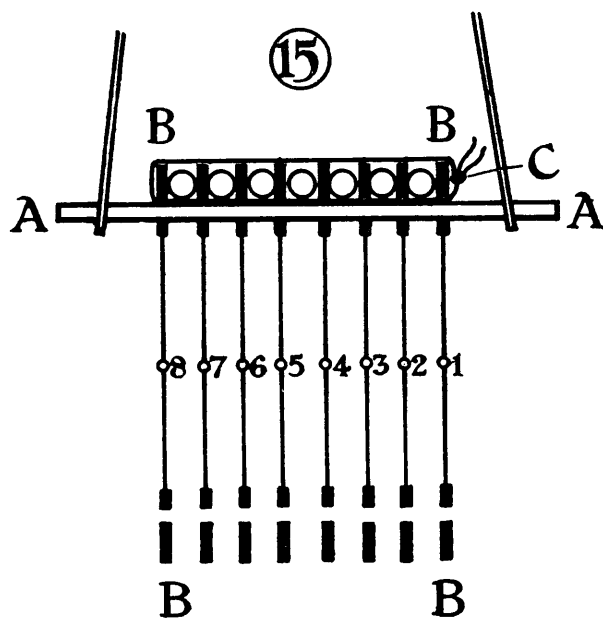

Fig. 15 the enclosed white circles are the short pieces of rod and at C the ends of the cord are shown which binds the top laths of the headles and the pieces of rod together.

For the simple plain weaving loom, the harness of which is shown at Fig. 2, Chapter II, all that is necessary for the entering is to separate the two sets of eyes as shown

in Fig. 16 and tie up the handles so as to keep the headles from shifting.

The numerals in both Figs. 15 and 16 indicate the order of entering. It may be noted also that it will be found most convenient in both cases to unscrew the reed holder from the iron rods and remove it whilst entering the harness, but it can be replaced when the reed itself is to be entered.

When the entering is finished the warp has to be attached to the front roller in exactly the same manner as in the full sized treadle loom. The student is referred therefore to the last paragraph on page 66 of *Weaving for Beginners*, where full directions for this important work will be found. The directions begin at page 66 and end with the first paragraph on page 69.

All these preparations having been properly made the table loom will be found ready for the weaver to regulate every part of the mechanism and begin weaving. How to do this must be treated of in another chapter.

The firmness or coarseness of the web to be woven will depend entirely on the number of dents or openings to

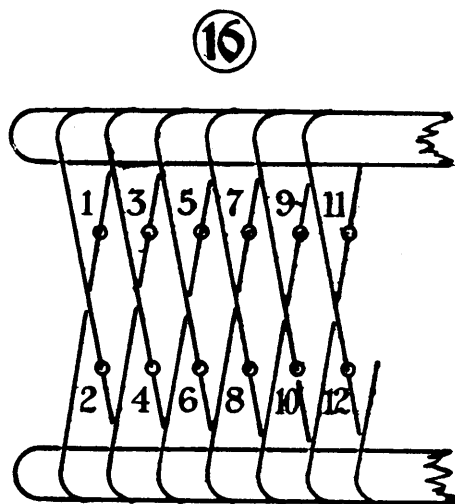

the inch in the reed. As a general rule *two* threads are entered in each dent so that the threads passing through *two* headles are contained in each dent. Unless otherwise ordered the simple, two headle loom has a reed of twelve dents to one inch and the ornamental loom has twenty dents. The warp for the former consequently

17

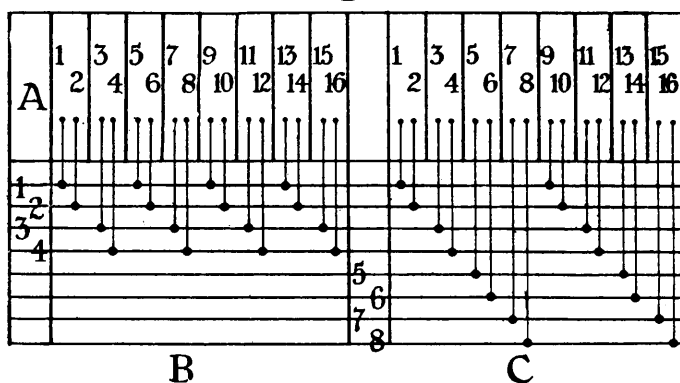

will have to be twenty-four threads to one inch and that for the latter forty threads. It will make no difference in this respect what number of headles are used as the entering will be as shown in the diagram, Fig. 17 at A, B and C, in which the headles are represented by the horizontal lines over B and C, the reed by the vertical lines to the right of A and the entering by the numerals. It will be seen at once that the same number of threads, in this case sixteen, are simply spread by the enterer over the greater number of headles and that the same *reed entering* will do for both.

CHAPTER V
REGULATING OR GATING THE LOOM
FOR WEAVING

THE side cords can now be removed, the warp tightened up by means of the ratchet of the front roller and, in the case of the loom with more than two headles, the slings, which have hitherto held the headles level with the front and back bars of the loom, can be taken down and put by for future use. It will now no doubt be found that the headles hang very unevenly so that the warp passing through each headle is at a different level to all the others: this will, of course, prevent the warp in the reed at the front presenting, as it must, an unbroken horizontal line when the loom is at rest. The utility of the joint at H in the pulley cords of the headles shown in Fig. 8 will now be realized, as, by its means, as described at page 17, each headle can be either raised or depressed at will and this must be most carefully done until the line of warp in the reed is unbroken and the warp from the front bar of the loom to the back one is perfectly level. When this is all finished, the table loom will have assumed the appearance of that shown in the frontispiece, except that the actual weaving of the material has yet to be started.

CHAPTER VI

GETTING TO WORK

IN addition to the loom set up with its warp ready for weaving the weaver will, of course, require a few tools, the most important of which is the shuttle for holding the spool of weft and interlacing it with the warp. A full description of these will be found in Chapter X of *Weaving for Beginners*, and therefore need not be repeated here. For the most part the Chapters XI, XII and XIII on getting to work, in the same book, apply equally to the treadle loom and the table loom, but a few special points of difference in starting the latter must here be noticed. The most important difference arises from the fact of there being no *treadles* or *tying* up required in the case of the table loom. The place of the treadles and tie up is taken by the handle at the side, in the case of the simple plain weaving table loom, and by the strings and pulleys in the ornamental weaving loom. These must now be carefully described and their use made clear.

If we turn to Fig. 2, page 5, it is apparent that the eyes of the healds which are on alternate threads can be raised and depressed in two sets, one set on odd threads and the other on even threads of the warp by turning the handle A half-way round backward and forward, and that each half revolution will make an opening in front of the reed with a different set of threads at the top,

first all odd numbered threads, 1, 3, 5, 7, etc., and second all even numbered threads, 2, 4, 6, 8, etc. It is also obvious that if a continuous thread of weft be passed through each successive opening, made by turning the handle, the warp and weft will be intersected and cloth will be woven.

In the mounting Fig. 3 plain cloth can be made by pulling down first the four beads, 1, 3, 5, 7, from the row E E and slipping the cords into the grooves immediately below at F F; this will make the first shed of odd threads. The second shed of even threads is next made by pulling down the beads, 2, 4, 6, 8, and replacing the white ones. This arrangement will not, of course, weave plain cloth quite so quickly as the handle and roller motion of Fig. 2. This loom is, however, made especially for pattern weaving, twills, satins and fancy figures such as those of Plates III, IV, V, and VI, though occasionally spaces of plain cloth may be required.

The only other difference between the working of the table loom and the loom described in *Weaving for Beginners* is in the substitution of the ratchet on the back roller for the friction weight. This special ratchet enables the weaver to let off, by raising the long lever at the side of the loom (*see* frontispiece), sufficient warp to make about two inches of cloth without moving from the front of the loom. The warp is tightened up by moving the small toothed ratchet at the front in the opposite direction to the large toothed one at the back.

With the above exceptions all the directions for fixing the warp to the front roller and getting to work given in *Weaving for Beginners* are equally applicable to weaving on the table loom.

CHAPTER VII
THE POSSIBILITIES OF VARIETY IN
TEXTURE AND PATTERN ON THE
TWO-HEADLE TABLE LOOM

OF course, the possibilities of varying the appearance of the web, produced on the two headle loom, is limited to what is called by weavers *tabby* weaving, but generally known as *plain* weaving. Pure handwork, called *brocading*, can be used, more or less profusely, in addition to the automatic working of the headles and by this means highly ornamental designs may be added to the plain web in spots, bands or continuous patterns. Plate I is an illustration of this composite treatment. The ground web is woven twenty-four double threads of mercerized cotton to an inch and the lighter colour of the bordering is arranged in the warping. The small floral sprigs arranged symmetrically in rows and the larger floral group in the centre are *brocaded* in different coloured silks as described in Book I of this work, Chapters IX, X and XI, the only difference being that on the weaving board there described, the tabby ground is woven entirely by hand as well as the brocading.

Notwithstanding, as suggested above, that the two headle loom is restricted to tabby weaving its plain texture may be varied considerably. We must now, therefore, consider how this can be done. (1) Fine or

PLATE II.



coarse threads may be used for the warp ; coarse worsted with as few as sixteen threads to an inch or fine linen of 200 threads to the same space will naturally make material of a totally different texture. (2) The weft or interlacing thread may also be coarse or fine and its proportional size to the warp may result when woven in textures as far apart as a coarse worsted tweed, a fine silk taffeta or an Irish poplin. (3) The use of thread made from different kinds of raw materials either in warp or weft will result in materials soft and glossy as silk, harsh or rough as wool, uneven and stiff as linen or pliable and smooth as cotton. (4) Colour or dye affords opportunity for variation on plain webs whatever kind and size of the thread used. The warp and weft may be of different colours, when the result will be a shot effect, as it is called. Stripes of different colours and proportions may be arranged by the warper and highly ornamental effects obtained without extra work by the weaver as in Plate II, which is a piece of East African native weaving, woven in narrow strips and the strips sewn together with a needle. Stripes in the *weft* can also be designed, but for these the weaver has to be responsible. Great care has to be taken, if the stripes are to be kept even, to weave in the proper number of different coloured shoots of weft to form each of the stripes and the spaces of ground between them. When both warp and weft stripes are used the design called tartan or plaid results. Chapter XIV of *Weaving for Beginners* explains fully this branch of plain weaving and gives directions for designing and arranging for it. (5) The inlaying or brocading of ornament in plain tabby webs, referred to above, such as can be woven on this simply

mounted table loom, affords almost unlimited scope for his invention and skill to the artist craftsman in the production of elaborate patterns as well as to the beginner for weaving in with the needle simple embellishments to decorate portions of the web : small geometrical spots, floral shapes and sprigs, wavy and broken lines, etc.

CHAPTER VIII
ORNAMENTAL WEAVING ON THE MULTI-
HEADLE TABLE LOOM

WE have seen that even on the loom with only two headles a considerable variety of fabrics can be woven, especially if more or less elaborate brocading be added to the plain weaving. It will, therefore, be

(18)

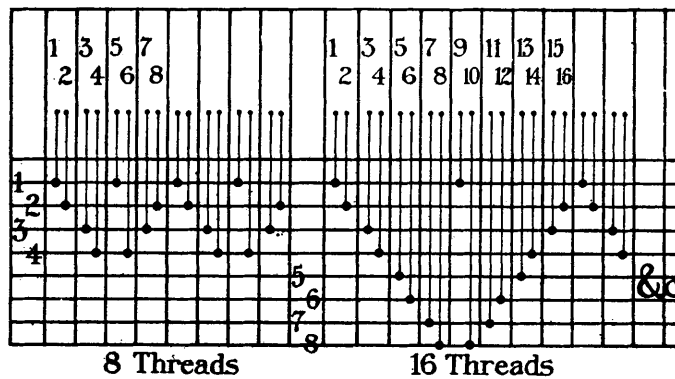

readily understood that if the harness of the loom consists of eight headles instead of two, the facilities for variety of texture will be considerably increased. Not only, however, can more elaborate plain textures, such as twills, satins, etc., be woven with an increased number of headles, but many small effective ornamental designs can be woven automatically, according to patterns worked out on ruled paper, as will be presently explained.

The frontispiece shows a loom with a mounting of eight headles, but that number may be increased to twenty or reduced to four. The order of entering the warp in the harness may also be altered so that instead of being entered straightforwardly as in Fig. 17, B and C,

19

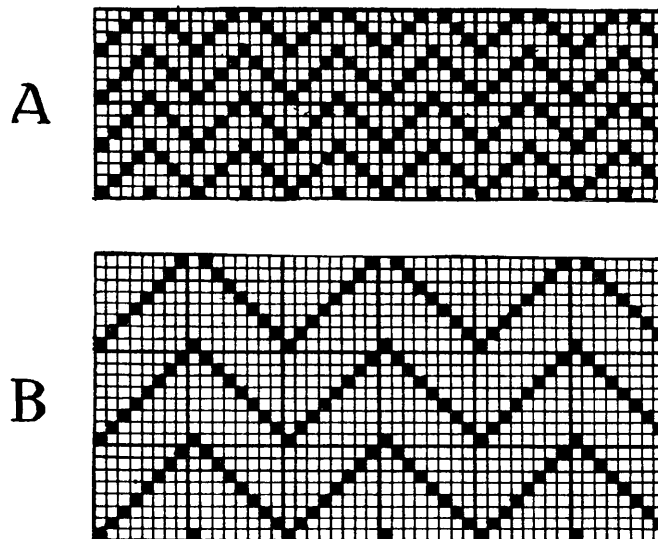

it may be entered in what is called a diamond entering as in Fig. 18, so that if the beads of the harness were pulled down in regular succession the number of threads affected by four headles will be increased to eight and the number of threads affected by eight headles will be increased to sixteen, consequently the woven effect would be extended as shown on the ruled paper at Fig. 19, A and B. There are many other more complicated

enterings, but these examples are sufficient for the present explanation.

Plain tabby, Fig. 20, C, may be woven on both the above enterings in the same way as directed at page 29, but with the entering Fig. 18, ordinary twills Fig. 20, A and B, cannot be made. The weaver always tries, whatever entering a special design may require, to so arrange it that plain tabby weaving can be alternated with any ornamental figure he may be weaving.

The effect of Fig. 19 is the result if the beads of the headle frame are worked repeatedly in the order 1, 2, 3, 4 or 1, 2, 3, 4, 5, 6, 7, 8, with the entering of Fig. 18 ; but if they are worked in the order 1, 2, 3, 4, 3, 2, 1, or 1, 2, 3, 4, 5, 6, 7, 8, 7, 6, 5, 4, 3, 2, 1, the diamond effect A or B, Fig. 21, will result. Hence, this entering is called the *diamond* entering, whilst the straightforward threading is called *plain* entering. Other enterings will be indicated in the specifications for special designs as they are required later on, but these two are the most usual ones.

20

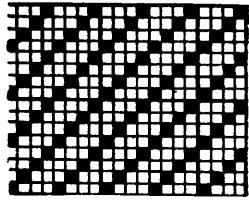

A

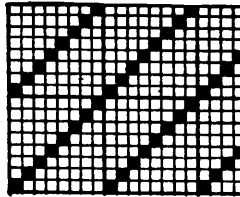

B

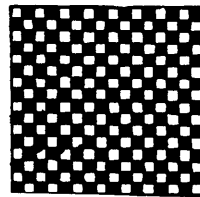

C

21

A

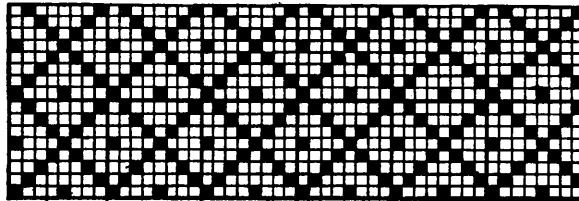

B

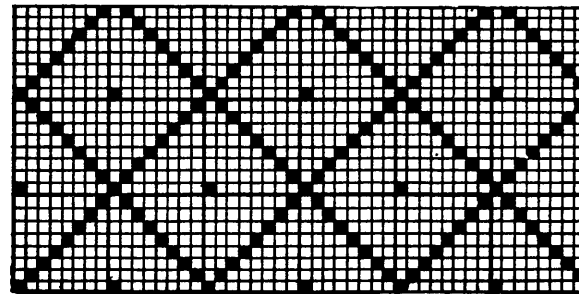

CHAPTER IX
FLUSHING, THE BASIS OF ALL
ORNAMENTAL WEAVING

OF course, all that has been advanced as regards texture and ornamental *brocading* on the simple, two headle loom, is applicable to the loom fitted with an increased number of headles. In addition to these, however, a vast range of designs formed by passing or *flushing*, as it is called, the weft or warp over an arranged *group* of threads, instead of *every alternate* thread as in tabby weaving. This will be made quite clear if Figs. 19, 20 and 21 be re-examined. Fig. 20, C, represents plain tabby weaving in which the intersections of *single* threads of warp and weft are invariable. This effect can be got as already described on two headles, but it can also be woven with any *even* number of headles, 4, 6, 8, 10, etc. All that is necessary is to arrange for all the headles entered with the odd numbered threads to rise alternately with all those entered with the even ones. For instance, take Fig. 17, if, instead of raising the four headles in regular succession, Nos. 1 and 3 are raised together and, in alternation with them, headles 2 and 4 are raised, the tabby effect of Fig. 20, C, will be woven. The student should prove this once for all by drawing out on ruled paper all the examples in the group from Figs. 17 to 21. He should also note and confirm that when the headles are raised in regular succession,

as in all the examples, Figs. 17, 18, 19, 20, and 21, except C, Fig. 20, *flushing* occurs between the intersections indicated by the black squares. In Fig. 20, A, it is over *three* squares or threads. In Fig. 20, B, the flushing is over *seven* squares, and in Fig. 19, A and B, and in Fig. 21, A and B, the flushing is over from *three* to *fifteen* threads.

This is a very important point and should be thoroughly understood by the student, for it is by means of causing the warp or weft to flush over certain selected threads that all automatic pattern weaving whatever is effected.

CHAPTER X

TWILLING ON FOUR HEADLES

FIG. 20, A and B, are diagrams of a texture the technical name of which is *Twill*: the original spelling of the word was *Tweel* and the method of making various ornamental fabrics of which the twill is the foundation was called *Tweeling*.

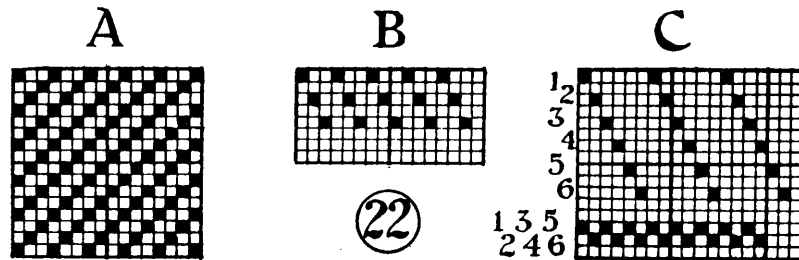

The smallest number of headles on which a twill can be made is *three*. In this twill the web passes under one thread of warp and flushes over two threads, *see* Fig. 22, A, and the entering is as shown at B in the same figure.

Looms are seldom mounted with only three headles because it is not possible to weave tabby cloth unless there are an equal number of odd and even threads in the entering. If a three headle twill is required it is generally woven on a harness of six headles entered as at C Fig. 22. With this harness, it will be seen,

an equal number of odd and even threads are available for tabby weaving as shown below C, and a three-headle twill can be arranged for by always lifting two headles together. Thus, in the first line, Fig. 22, the first and fourth headles are lifted together. In the second line the second and fifth lift together. In the third line the third and sixth are lifted together and this completes the sequence, as the fourth line is the

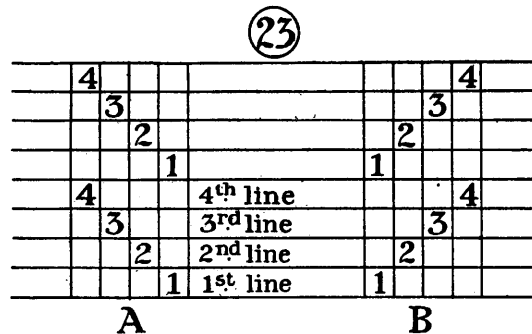

same as the first. From this it will be realized that it is always most convenient to have a loom mounted with an even number of headles.

A harness of four headles being the nearest even number to the tabby harness of two headles, let us see what variety of twilled texture it can be used to produce. Plate III gives twelve specimens of twill textures which can be woven on a harness of four headles.

No. 1 is what is called a biased or regular twill, because its intersections follow each other in regular sequence, in diagonal lines and always at an equal distance apart, in this case, the space of three threads both of warp and weft. These biased lines may be made, at will, to

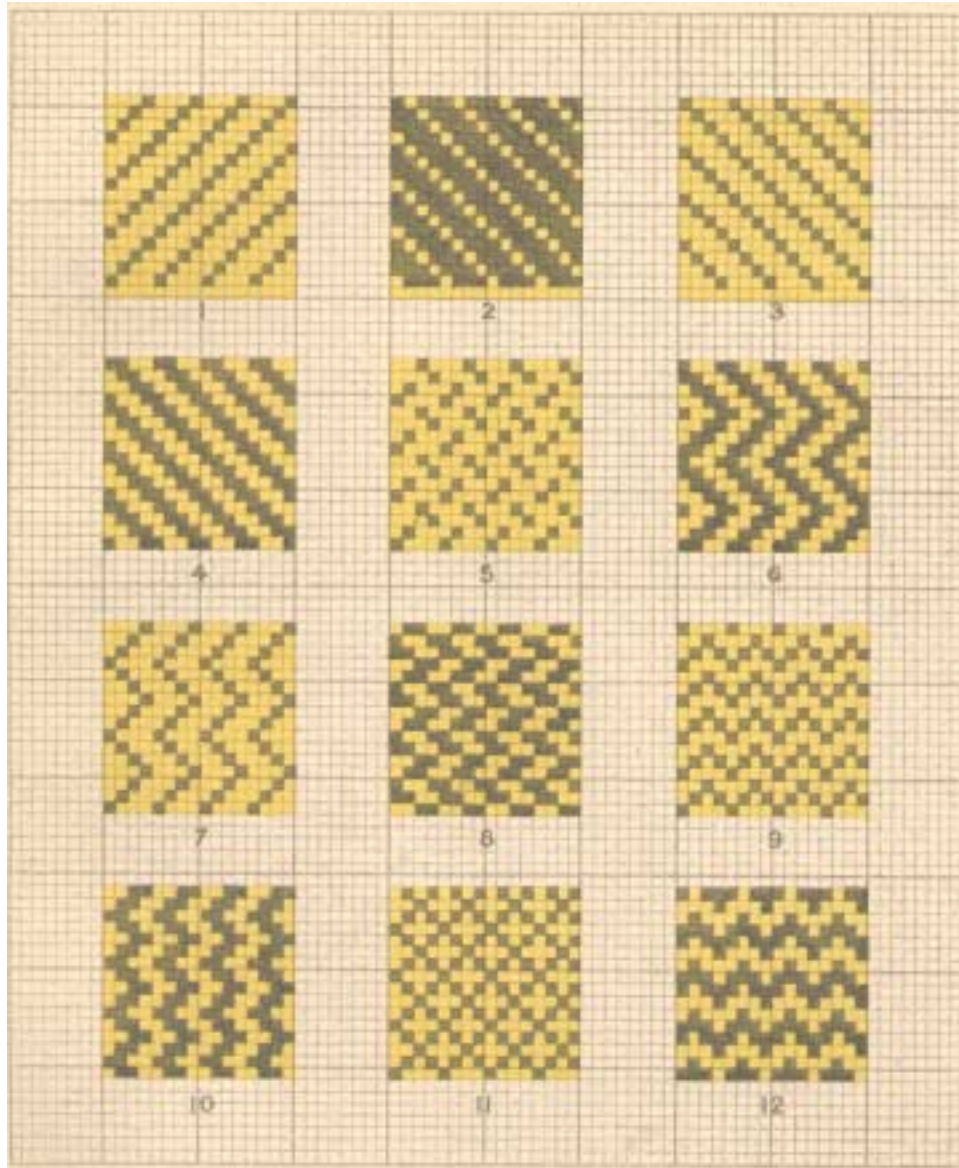

incline either to the right or left according to the order in which the headles are lifted. In No. 1, Plate III, the headles are raised, by pulling down the beads and fixing them in the lower rack, in the order indicated by the numerals in Fig. 23, A.

It will be remembered that the entering of the warp began at the first heald on the back headle of the harness : accordingly the first line of weft will pass under the threads lifted by the first or back headle. For No. 3,

(24)

		2		6 th line			2		
		3		5 th line				1	
	4			4 th line	4 th		3		
		3		3 rd line	3 rd	4			
			2	2 nd line	2 nd			2	
			1	1 st line	1 st				1
A					B				

Plate III, the order of lifting shown at letter B, Fig. 23, must be observed.

For No. 7, Plate III, the succession given at Fig. 24, A, must be worked. In this case there are six lines of weft in each repeat.

No. 5, Plate III, works out on four lines of weft in the manner shown at letter B, Fig. 24. This is called a *broken twill*. This effect will be explained later.

It must be noticed here that the regular twills, of which the above are specimens, have a peculiarity which is at the foundation of all ornamental weaving, *especially the weaving of figured damasks*. It is that the proportions of warp and weft showing at the front and back of the web are different. If a piece of stuff having, for

CHAPTER XI
BROKEN TWILLS

NO. 5, Plate III, is an example of a texture in which, at certain intervals, the diagonal line of the twill is broken by intercepting the regular succession of the headles in the process of weaving. This is called *satinet* texture and illustrates the principle on which the

(26)

	3			4 th line		3	2		
	4			3 rd line		4		2	1
		2		2 nd line				2	1
			1	1 st line		4	3		
A				B					

			1	4 th line	4	3		1	
	3			3 rd line	3 rd	4			
	4	2		2 nd line	2 nd			2	
			1	1 st line	1 st	3	2	1	
C				D					

4 th	4	2		
3 rd		3		
2 nd	4	2		
1 st			1	
E				

very important class of materials known as *satins* are designed.

Satins, more or less perfect, may be woven on any number of headles up to twenty-four, but the present example is on the smallest possible number of headles that the effect of satin can be produced by.

The plan for weaving satinet, No. 5, Plate III, is given in Fig. 26 at letter A.

No. 8, Plate III, is a variant of No. 5 and is woven on the plan given at B, Fig. 26.

No. 9 of the same Plate gives another effect which although not a true satinet is akin to it. Plan C shows the method of weaving this texture, and the plan D, Fig. 26, which in many respects is similar to it, will work out like No. 12, Plate III. No. 11, Plate III is woven on the plan given in Fig. 26 and is akin to No. 9. It forms a tiny trellis design.

In connection with this chapter the student should consult *Hand-Loom Weaving*, before referred to, Chapter XI, pages 164 to 178, where directions are given for extending four headle twills into quite extensive designs by means of the *diamond* entering described at Fig. 16 of this book. The limits of the present volume will not admit of further consideration of the capacity of a four-headle harness here, and we must pass on to illustrate in the next chapter what can be done if the number of the headles is increased to eight.

CHAPTER XII

TWILL DESIGNS ON EIGHT HEADLES

NATURALLY all the tabby and twill textures that can be woven on a harness of four headles can be woven on one of eight. In such case the design will be repeated twice on eight threads of warp as shown

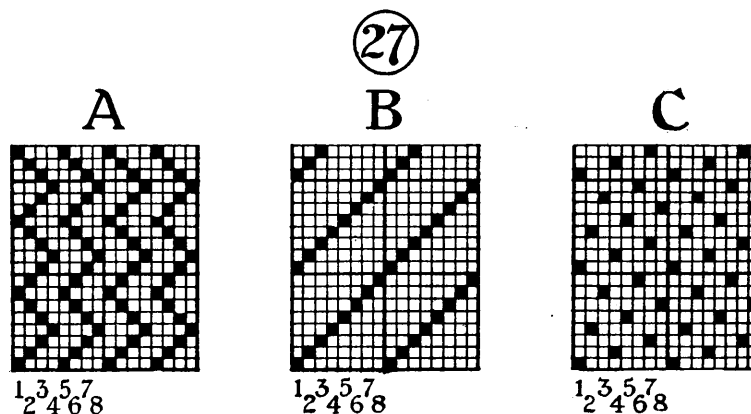

in Fig. 27, letter A, where the repeats are indicated by the numerals below the diagram.

It should be noted here that the increase in the number of headles only affects the number of *warp threads* actuated counting *laterally*, so that a twill on eight headles repeats as shown at B, Fig. 27. Also it should be noted that the height of a design is not limited by the number

of headles it is woven on ; it may be extended from three shoots of *weft* to any number the designer can make use of.

The numerals below the diagrams B and C, Fig. 27, indicate the several threads of warp which are entered in consecutive order through each of the eight headles, the same entering being used for both the twill at letter B, or the most useful of all broken twills or satins, letter C. The order in which the headles are to be lifted for the designs A, B, and C, Fig. 27, are given in Fig. 28, A, B, and C.

Where, as in regular twills, the beads have to be pulled down in regular sequence, it is easy to remember the right

(28)

A					B												
Lines	8 th	7 th	6 th	5 th	4 th	3 rd	2 nd	1 st	Lines	8 th	7 th	6 th	5 th	4 th	3 rd	2 nd	1 st
			6			2				8							
		7			3					7							
	8			4						6							
			5			1				5							
	8			4						4							
		7			3					3							
			6			2				2						2	
				5			1			1							1

C							
8 th	7 th	6 th	5 th	4 th	3 rd	2 nd	1 st
		6					
					3		
	8						
			5				
						2	
	7						
						4	
							1

succession of bead after bead ; but in the case of satins the weaver is apt to forget which exact line of the design he is on, and may consequently raise the wrong headle. In satins, therefore, it is possible so to arrange the pulley cords that the beads may be pulled down from 1 to 8 in the same order as for a regular twill. Fig. 29 will illustrate this matter. This Fig. (29) represents the side of the headle frame of the loom with its bead rack A, A, A, A, at the bottom and its pulleys B, B numbered 1 to 8 at the top.

In this diagram the crossing lines drawn between B, B, and A, A, are the pulley cords which connect the beads in the rack A, with the pulleys and the headles. Pulley cord 1 goes direct to bead 1, cord 2 goes to bead 4, cord 3 to bead 7, cord 4 to bead 2, cord 5 goes direct to bead 5, cord 6 to bead 8, cord 7 to

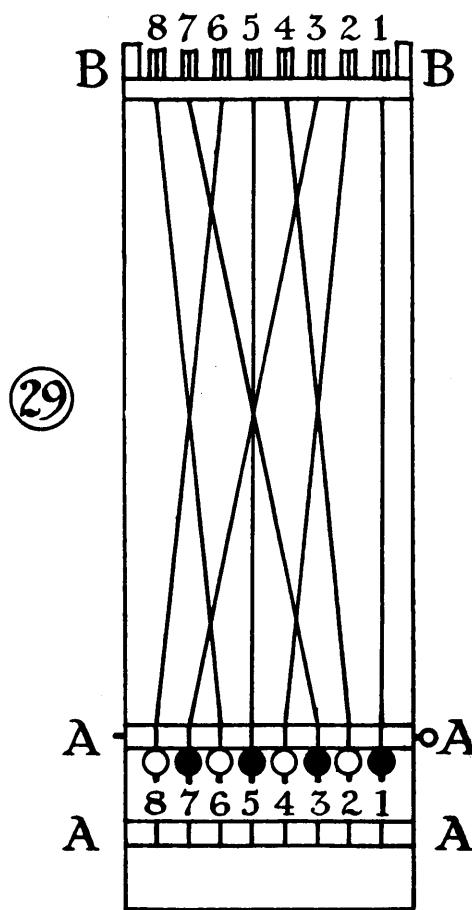

30

8	7			4			
8	7	6			3		
	7	6	5			2	
		6	5	4			1
8			5	4	3		
	7			4	3	2	1
		6			3	2	1
8			5			2	1

1st Shoot

A

8	7				3		1
8			4		2	1	
			5		3	2	1
		6		4	3	2	
	7		5	4	3		
8		6	5	4			
	7	6	5				1
8	7	6				2	

1st Shoot

B

	7				3		1
8				4		2	
			5		3		1
		6		4		2	
	7		5		3		
8		6		4			
	7		5				1
8		6				2	

1st Shoot

C

bead 3, and cord 8 to bead 6. Thus, crossing each other between A and B, the cords can be pulled down in regular succession, as shown by the numerals beneath the row of beads in the rack, and at the same time draw up the headles necessary for forming the satin, letter C, Fig. 27.

In thus arranging for the cords to cross each other it may be necessary, especially if much of the satin is to be woven, to slightly lengthen some of the cords by

PLATE IV.

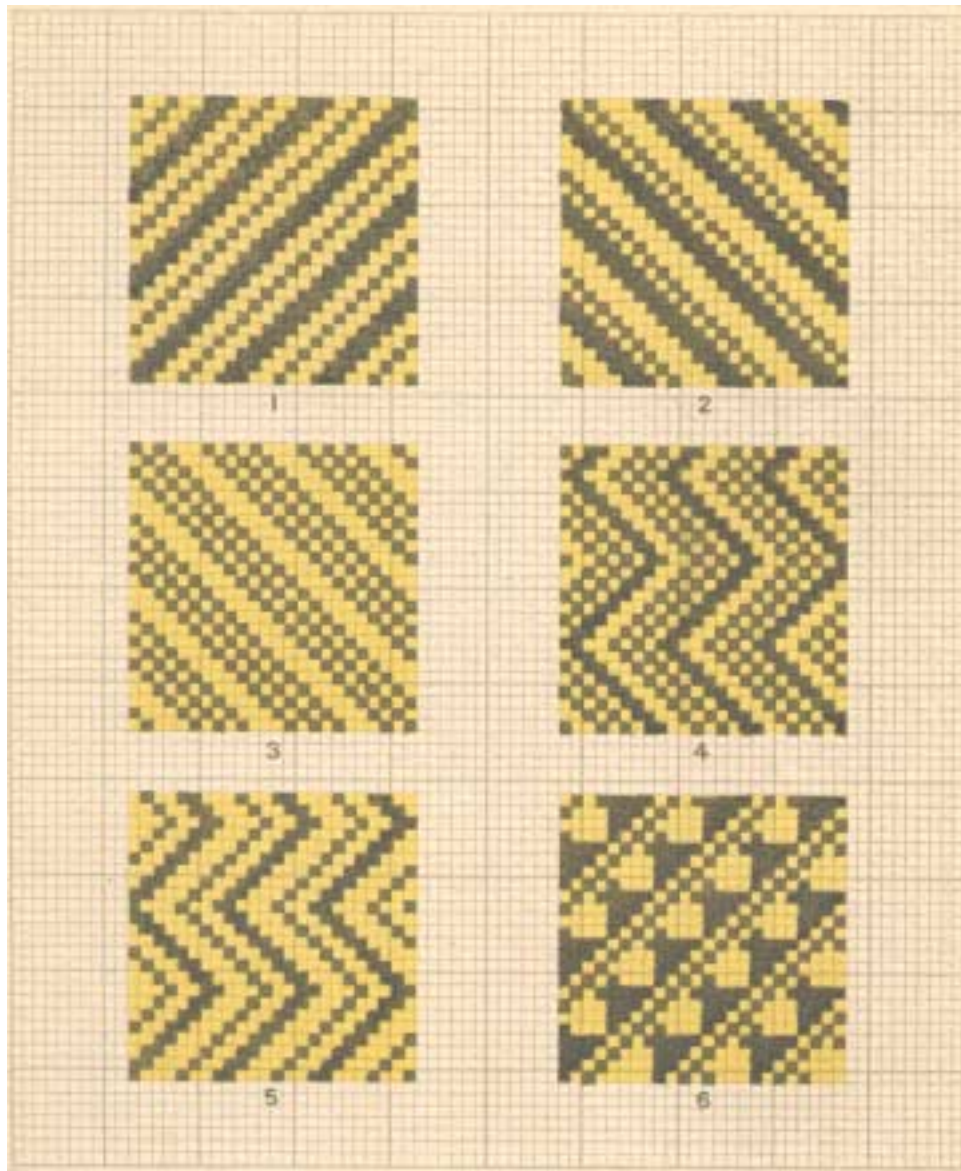

means of the slip loops between the pulleys at the top of the headle frame.

Another branch of twill weaving consists of what used to be called the *fancy* twills. These twills are illustrated on Plate IV, which contains only six specimens out of the very large number that can be designed.

It is only necessary to give three plans of these fancy

31

8	6	4		1	1 st Shoot
8	7	5	3	2	
	7	6	4	2	
		6	5	3	1
8		5	4	2	
	7		4	3	1
8	6		3	2	
	7	5		2	1
8	6		3	2	
	7		4	3	1
8		5	4	2	
		6	5	3	1
	7	6	4	2	
8	7	5	3		
8	6	4		1	1 st Shoot

8		5		1	1 st Shoot
	6			2	1
	7		3	2	
8		4	3		
		5	4		1
	6	5		2	
	7	6		3	
8	7		4		
	7	6		3	
		6	5		2
		5	4		1
8		4	3		
	7		3	2	
		6		2	1
8		5		1	1 st Shoot

A B

32

8	6	4			1 st Shoot
	7	5	4		1
8			4	2	
			4	3	1
8			4	2	
8	7	6	5	3	1
8	7	6	4		
8	7	5			
8	6	4			1 st Shoot

twill, as they are all worked in the same manner on eight headles and with the same straightforward entering as described in a previous chapter. The plans of 1, 2, and 3, are in Fig. 30, A, B, and C respectively.

The zigzag twill, whether plain, Fig. 27 A, or fancy, and whether vertical or horizontal, is called a wave, accordingly the Nos. 4 and 5, Plate IV, are wave twills. Fig. 31, A and B, gives the plans of these two examples.

The sixth and last specimen of a fancy twill for which space can be afforded is No. 6, Plate IV; its plan is given in Fig. 32 on page 47.

CHAPTER XIII
BIRDEYE DESIGNS ON FOUR HEADLES
OR EIGHT HEADLES

FIG. 33 gives the type of what were named by the old weavers *Birdeye* designs. They were generally woven on a harness entered with a *diamond draught* in a manner which will be fully described presently. The only advantage, however, of weaving them with a

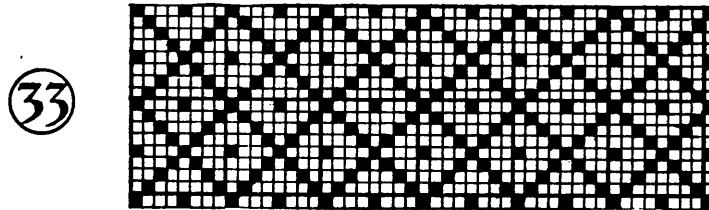

special entering is that fewer headles are required for the purpose. The straightforward entering with which all the patterns hitherto described are woven is more generally useful, and even a greater variety of *Birdeye* designs can be worked out on it, than can be done with the special entering usually made use of.

Plate V gives twelve examples of *Birdeye* designs. They are all founded on the crossing twill, or trellis, plan with a spot or *eye* in the centre of the diamond space. These of course are only a few specimens out of the very large number it is possible to design.

34

1

		4	4			8 th Shoot
	7	5	4	3		7 th "
8	6		4	2		6 th "
	7	5	3	1		5 th "
8	6		4	2		4 th "
	7	5	3			3 rd "
		6	4			2 nd "
			5		1	1 st Shoot

A

3

8					2	8 th Shoot
	7	5	4	3		7 th "
		6	4		1	6 th "
	7	5	3	1		5 th "
		6	4		1	4 th "
	7	5	3			3 rd "
8					2	2 nd "
		6	5	4		1 st Shoot

B

4

8			5	3		8 th Shoot
	7		4		1	7 th "
		6	5	3	2	6 th "
8	6			2		5 th "
	7		4		1	4 th "
8	6			2		3 rd "
		6	5	3	2	2 nd "
	7		4		1	1 st Shoot

C

6

			5	4	3	8 th Shoot
	7		4		1	7 th "
		6			2	6 th "
8			5	3		5 th "
	7		4		1	4 th "
8			5	3		3 rd "
		6			2	2 nd "
	7		4		1	1 st "

D

Working bead-rack plans for Plate V, Nos. 1, 3, 4, and 6.
Birdeye patterns.

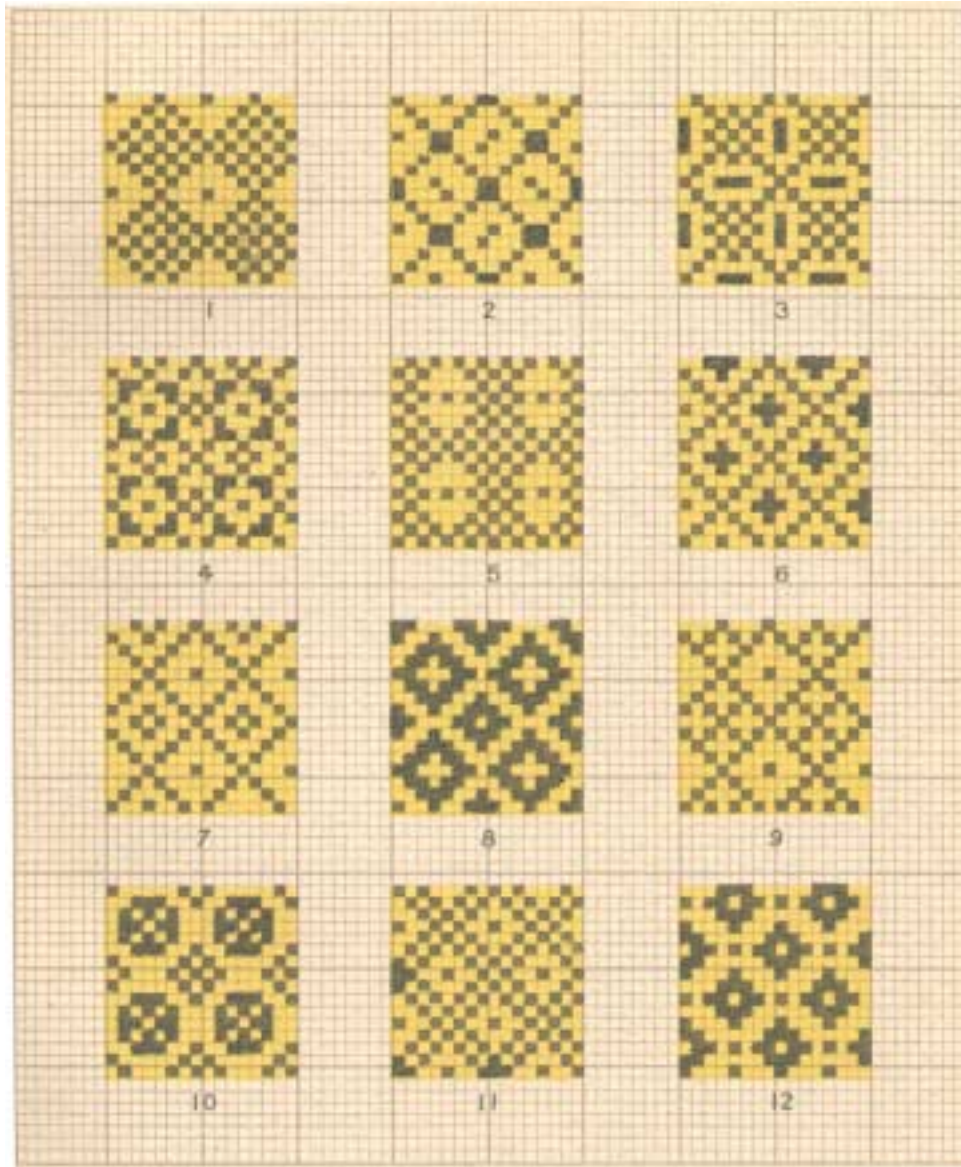

8								11									
	7	6				2	1	8 th Shoot		7			3		1	8 th Shoot	
8	7			4			1	7 th ..	8		6		4		2	7 th ..	
8			5	4	3			6 th ..		7		5		3		6 th ..	
		6	5		3	2		5 th ..			6		4			1	5 th ..
	7	6				2	1	4 th ..		7		5		3			4 th ..
			6	5		3	2	3 rd ..	8		6		4		2		3 rd ..
				5	4	3		2 nd ..		7				3		1	2 nd ..
8	7			4			1	1 st ..	8			5			2	1	1 st ..

E

F

12										
		6	5	4						8 th Shoot
	7	6		4	3		1			7 th ..
		6	5	4						6 th ..
			5				1			5 th ..
8							2	1		4 th ..
8	7		5		3	2				3 rd ..
8							2	1		2 nd ..
			5					1		1 st ..

G

Working bead-rack plans for Plate V, Nos. 8, 11, and 12.
Birdeye patterns.

The only instructions necessary to give in regard to these patterns is that the weft and warp must be of the same thickness, and the weft must be laid the same

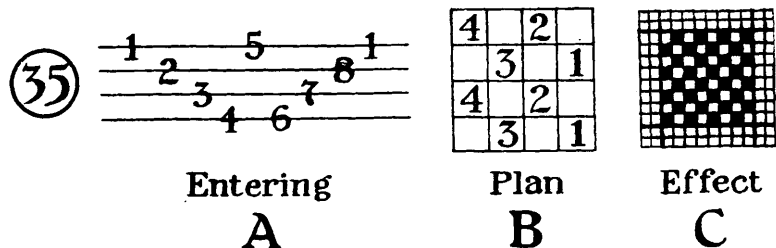

number of shoots to the inch as there are threads of warp in the same space so as to work them four square.

The disadvantage of the diamond, or any other special

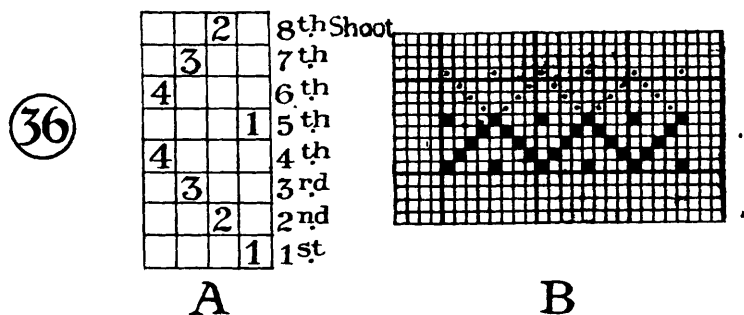

entering of the warp is that it limits the number of patterns possible on the loom far more than the straight-forward entering we have hitherto considered in this book. This is so notwithstanding the fact that it gives four headles command over as many threads of warp

PLATE VI.



in each repeat of the design as is the case on eight headles with the ordinary entering.

The diamond entering is particularly disadvantageous in that twills, and the immense variety of designs founded on them, cannot be woven on it.

The diamond entering is chiefly used for weaving embellishments, bands of ornament, and such-like, at intervals on tabby grounds, for it does not prevent plain

37

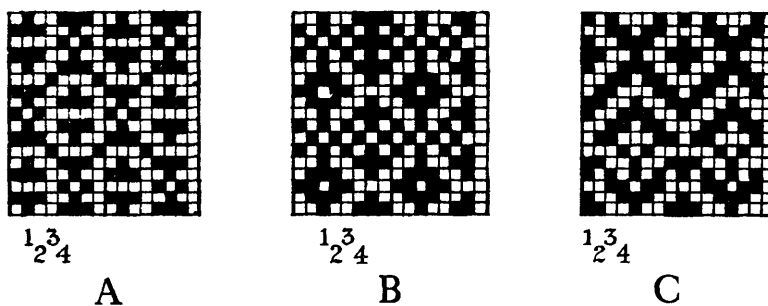

tabby weaving being done. This is shown by Fig. 35, A, B, and C.

Thus, on four headles entered as in Fig. 35, A, the Birdeye design, Fig. 32, can be woven according to the simple plan Fig. 36, A.

The 1st headle will raise the 1st and 5th threads	
The 2nd " " " 2nd " 8th "	
The 3rd " " " 3rd " 7th "	
The 4th " " " 4th " 6th "	

The effect so far is shown on ruled paper at B, Fig. 36. Then to continue and complete the design, as at Fig. 32,

the first headle must rise again and fill the dotted squares on the fifth line. Next the fourth headle followed in turn by headles three and two will fill the sixth and seventh and eighth lines and so finish the pattern, the repeat of which will begin of course with headle No. 1.

Many variants of the Birdeye and other designs in which the diamond entering is used can be arranged for on four headles by the ingenious designer. Three

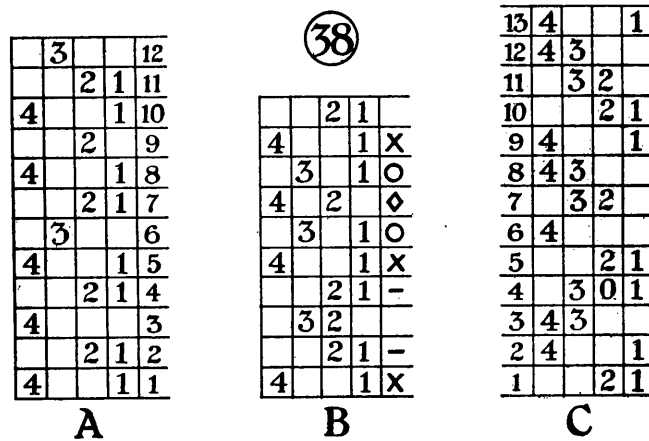

examples are given in Fig. 37, A, B, and C. At letter A is a design which has *eight* warp threads in the width and *twelve* shoots of weft in the height, of each repeat of the pattern.

Fig. 38 gives the plans of the three designs above and it will be seen that there is apparently no provision made for raising the fifth, sixth, seventh, and eighth in each design. This is because the threads are always lifted in pairs (*see* Fig. 34, A). The designer will find that

the fifth, the centre, thread of the harness is particularly difficult to manage.

It would be a good exercise at this stage for the student to carefully examine all the examples of pattern on Plate V and, where possible, make working plans for weaving them on headles. Such a study will prove very useful in preparation for advanced work on a full sized treadle loom, as the cording of the treadles can be done from any of the plans given for the table loom.

CHAPTER XIV
 TURNED OR REVERSED TWILLS—THEIR
 VALUE AND CONSTRUCTION

WE have already remarked that in regular and broken twills, or satins, the greater proportion of warp is thrown, or *flushed* to the front of the cloth and the greater proportion of weft is flushed at the back. We also referred to this as the foundation of the most perfect of all pattern weaving, viz. : Diaper

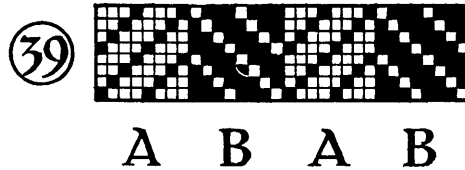

or Damask weaving. In this chapter the principles and mechanism on and by which this branch of weaving is done will be illustrated and explained by two or three examples such as can be readily woven on the table loom with eight headles.

The simplest kind of pattern that it is possible to form by thus contrasting a twill and its reverse is a vertical stripe such as Fig. 39.

At A A, Fig. 39, the weft shows only in small spots and affects the warp only in proportion of 1 to 3, but at B B where the twill is reversed the weft shows in the

proportion of 3 to 1. The method of weaving this effect, which requires six, eight or any even number of headles and a special entering, is shown by the Fig. 40, A and B.

This design of stripes (Fig. 39, A and B) requires eight

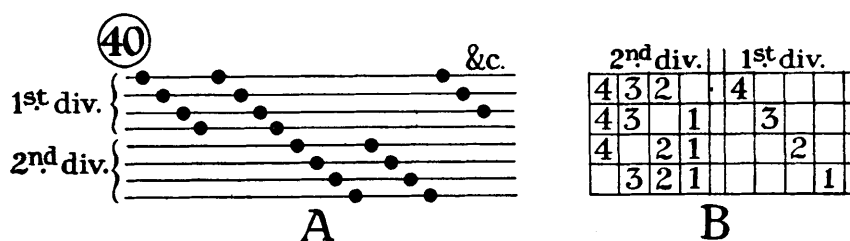

headles for the warp and the headles are entered in *two* divisions, as shown in the plan at A, Fig. 40. In working, *both* these divisions are used at the same time. If only

41

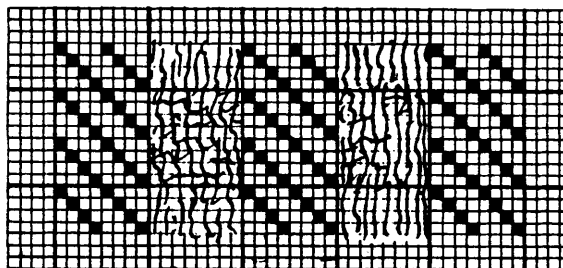

one, the first, division were used the woven effect would be like Fig. 41, showing vertical stripes of a four-headle twill with an unweaved space of the same width between each.

If both divisions working with the plan B, Fig. 40, were used together the effect of A and B, Fig. 39, would

result : that is a four-headle warp twill at A A, and the reverse, a four-headle weft twill at B B.

On this principle stripes of any width can be woven

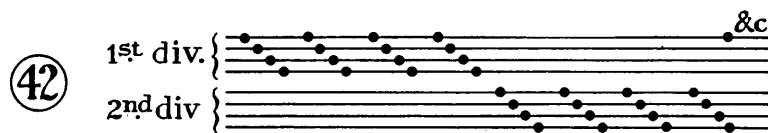

simply by entering larger groups of threads together on each division of the harness. Thus, the entering Fig. 42 will produce, with the same lifting plan, stripes of double the width of that of Fig. 40.

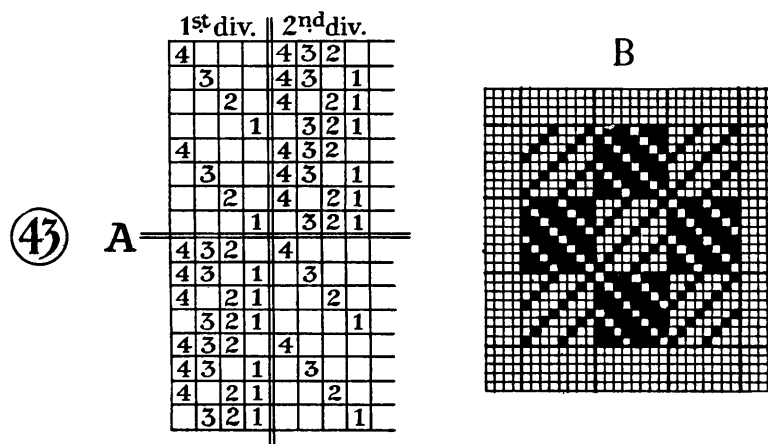

It is not, however, in weaving stripes but in the production of checkers, or dice patterns, of which so many varieties are possible, that the great usefulness of this diaper entering is most displayed. If, with the same entering, Fig. 40, the plan given at Fig. 43 is used, the result will be a checker, as at B, Fig. 43.

PLATE VII.

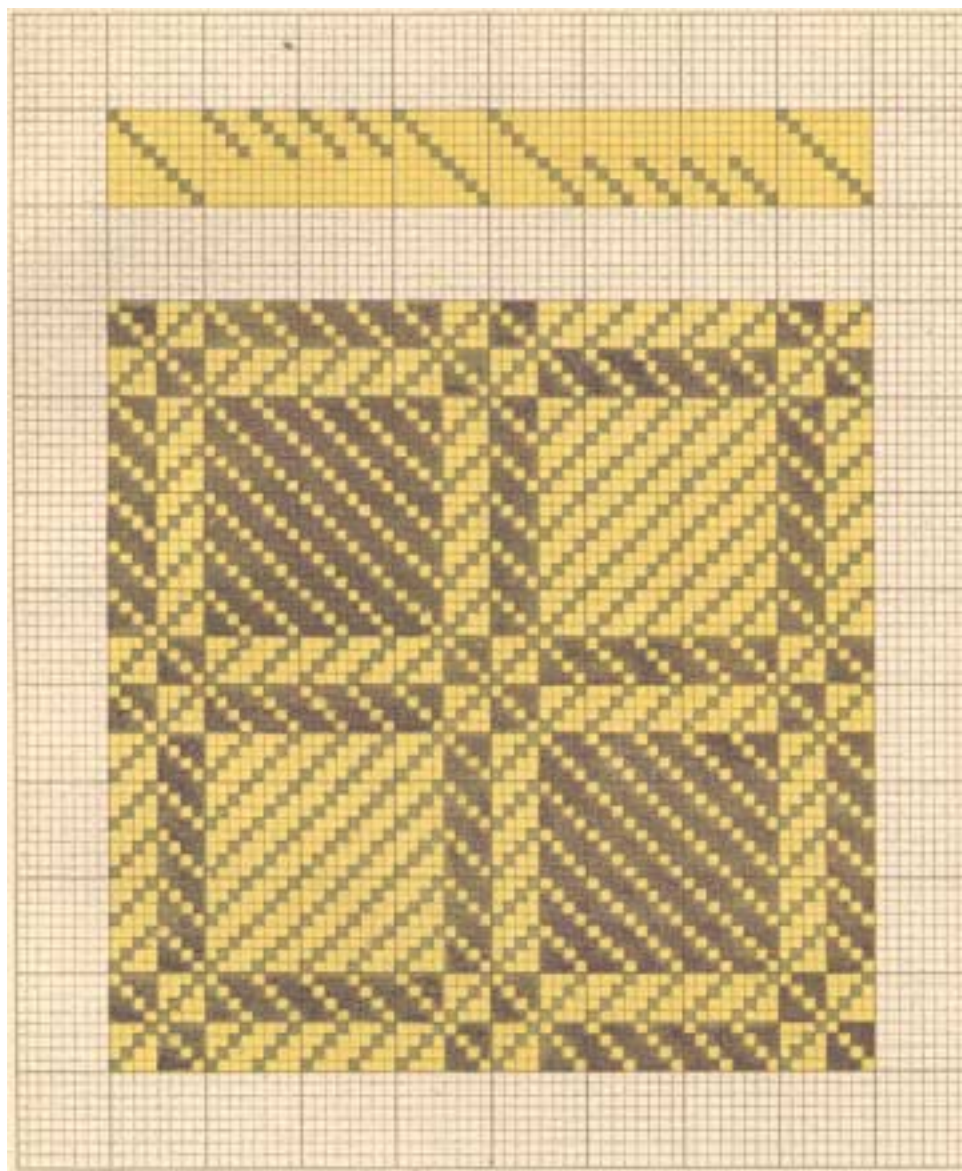

Plate VII gives an example of the pleasing variation that can be given to the checker design by slight alterations in the entering and wefting plans.

The space at disposal forbids a further development of this very interesting subject of diaper weaving, but sufficient has been explained to enable the student to experiment for himself with original inventions on the above lines.

CHAPTER XV

COMPOUND PATTERN WEAVING

TWO independent warps or two separate wefts working together in the loom are required in order to weave, automatically, designs of more or less complicated character and of broader effect than those we have hitherto described. Plate VIII displays a fabric of this class of weaving and is a good example of the simplest kind of what is known as *compound* pattern weaving. It is called *compound* because two warps, each on its separate roller, entered on two harnesses, one in front of the other, being worked simultaneously, enables the weaver to produce the complete web as shown in the illustration. Each of the two harnesses and warps has its own function: that of the front harness is to weave the ground or body of the cloth, and that of the back harness, in this case, is to bring up and flush over three shoots of weft three blue coloured threads of the second warp.

The front harness consists of two headles entered with greyish white cotton, twenty-four threads to an inch, while the back harness has the same number of threads entered in it, but they are spread over fourteen headles in groups of three, which are spaced and arranged on the headles in the same order as a diamond entering on ordinary single-thread harnesses. Fig. 44, letter C, gives a similar

harness spaced and entered on only eight headles because of the necessarily limited size of the diagram.

Fig. 44 is a diagram of the whole lifting mechanism of the mounting of the loom. A A is the reed, each opening of which is entered with two threads, one from the first headle of the ground harness B B, and the first one from the first group of the pattern harness C C. A careful examination of the diagram should make quite

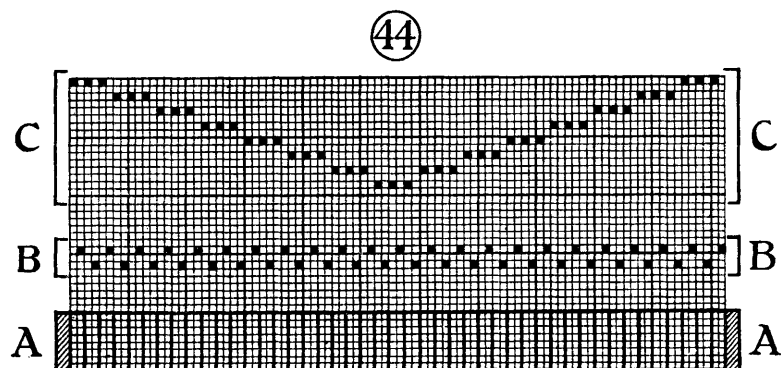

clear the entering of the two harnesses for one repeat of the design whatever it may be. It should, however, be pointed out that the threads of the separate warps are not entered in the eyes of both harnesses but being entered in the eyes of one harness pass *between* the leashes of the other.

It is not always necessary to space and arrange the back harness leashed in the form of a *diamond* entering, but there is a great advantage in doing so as the width of the design is thereby doubled without increasing the number of headles required.

Fig. 45 shows how this doubling, turning over or *pointing*, as it is generally called, is effected. The enclosed spaces A and B are of equal size and together form the

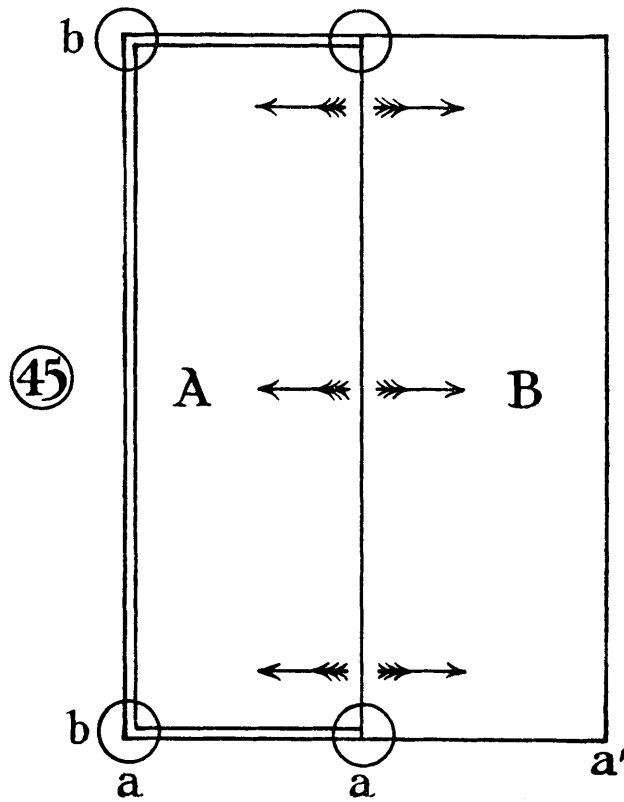

area of the complete design whatever it may be. The whole width of the area (a to a') may consist of any number of threads of warp either singly or in groups.

If the entering or arrangement of the groups on the headles is done in the ordinary straightforward way it is

manifest that the number of headles on which the design is to work will have to be sufficient to fill the whole space *a* to *a'*. If, however, the turnover or *point* arrangement is used the number of headles required will only be enough to fill the space between *a* *a*, just half the number. This, of course, simplifies the mounting of the loom and weaving and is a great advantage. Both spaces, A and B, are thus exactly alike except that whatever design is comprised in the space A is turned over in B space and points in the opposite direction (*see* the arrows, Fig. 45). The height of a design is not affected, for in both arrangements height is immaterial.

In order to make a design and weave it on a compound mounting such as Fig. 44 a drawing must first be made on paper ruled in squares, each square representing the number of threads (two or more) to be raised together in the pattern harness. Fig. 46 is such a design. It is made to work on fourteen headles lifting two threads together and arranged to turnover or point, as in Fig. 45. It therefore spreads over twenty-eight squares and covers fifty-six threads of tabby ground. If the same design were worked on a three-thread pattern harness it could be woven on the same mounting as the example on Plate VIII but would then be half as large again when woven.

Having made a design, the next thing is to work out in numerals the bead rack or tie up plan for the weaving. This is given in Fig. 47 which will explain itself. The above plan is numbered out to the full height of the design, but in working it is only necessary to draw it as far as the centre line, number 16, as the remainder can be read downwards until the first line is reached, which is exactly the same as the thirty-first.

Before beginning to weave Fig. 46 or any other design it will be necessary to see that both warps, after being fixed to the front roller of the loom, are stretched

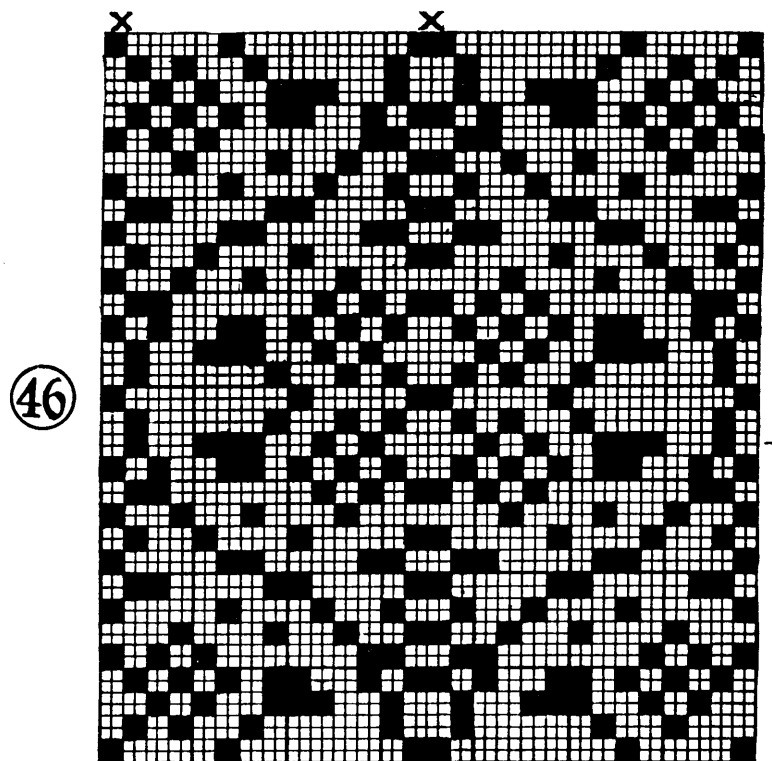

at sufficient tension to make them rise and fall readily when actuated by the treadles or drawcords.

The tension of the warps being nicely regulated, two or three inches of good, regular tabby cloth must be made independently of the pattern warp, which simply remains *below it unwoven*. The second warp being separately

47

14						6				1	31 st Line
	13					7		4	2		
	13		10	9	8			5	3		
14		12			9	8		6	4	2	
	13	12						5	3	1	
14			11			8			4		
	13			10				6			1
14					9	8				3	2
	13	12				7	6				1
14					9			5		2	
			11			7			4		1
14		12		10						3	2
	13		11		9		7	6		3	1
		12		10			7	6	5		2
	13		11			8					2
14					9						1
	13		11			8					2
		12		10			7	6	5		2
	13		11			9		7	6		3
14		12		10						3	2
			11			7			4		1
14					9			5		2	10 th
	13	12				7	6				9 th
14					9	8				3	2
	13			10				6			1
14			11			8			4		6 th
	13	12							5	3	1
14		12			9	8		6	4	2	5 th
	13			10	9	8			5	3	4 th
	13					7			4	2	3 rd
14							6				2 nd
								6			1 st Line

Centre

Edge of Design

weighted or stretched will not be mixed up with the tabby warps or interfere with the weaving of it in any way.

As soon as a good solid piece of tabby cloth is woven the whole of the pattern warp must be raised by drawing all the beads and fixing them in the rack. This will, of course, bring all the pattern warp to the top and allow tabby weaving to be continued *below* it. On the beads being all released, the pattern warp sunk and tabby weaving continued, a line of coloured loops closely flushing over the space of tabby ground will be left on the surface of the web. If all the previous operations have been properly done the flushing will be regular and even and a trial of all the groups of pattern warp threads should be next made by raising all the pattern headles in succession and weaving three shoots of weft beneath them as indicated in Fig. 48 A, where each square may represent from two to twelve threads of pattern warp according to the number to the inch and the fineness of the yarn used.

At B, Fig. 48, the odd and even pattern headles are raised alternately, forming a coarse checker with an occasional break at the points marked X in the diagram. This break in the checker and the blunt point in the zigzag, A, can be avoided in two ways: (1) by dropping out the two threads marked by the arrows in A, Fig. 48, (2) by making use of the birdeye arrangement in which the first and fifteenth threads are lifted by the same headle. By both alternatives the blunt point is avoided, but in the second the advantage of getting a slightly larger design is balanced by the necessity of always raising the spot at the centre of the trellis or whatever form the design is cast in. (See Fig. 48, E.)

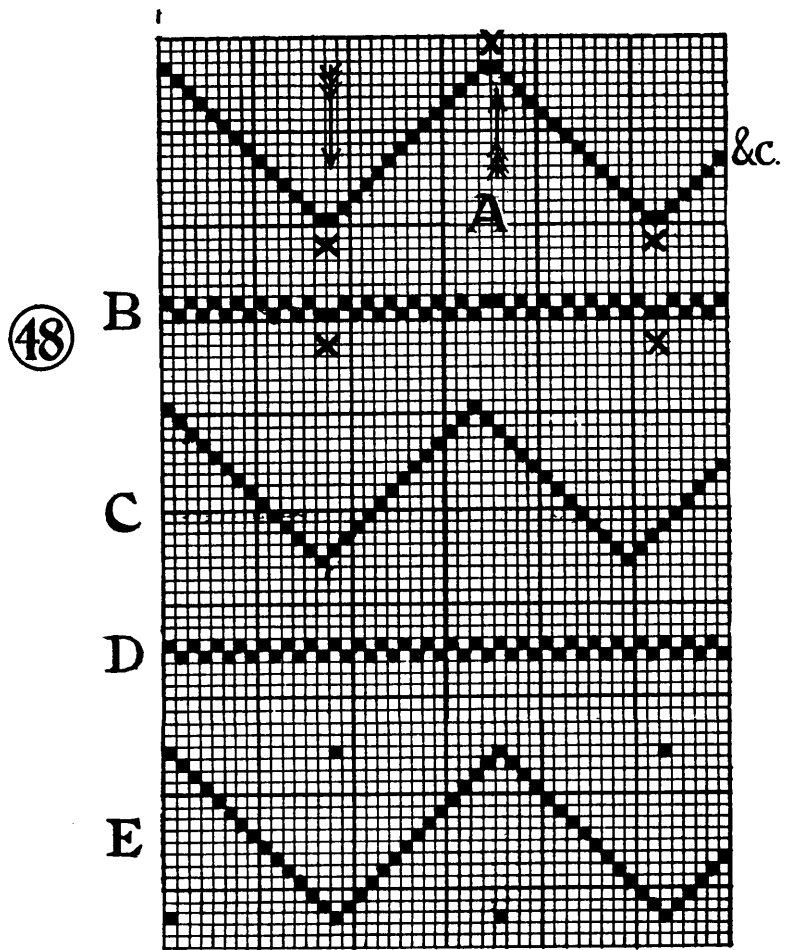

It is no use beginning to weave a design until this preparatory weaving has resulted in a satisfactory condition and working of both the warps and both the harnesses in all their parts. On careful examination all being found correct, weaving the pattern may commence by drawing the first row of the plan beads Nos. 1, 6, and 14, Fig. 47.

The threads being correctly raised, three shoots of weft must be woven as before and the reading of the second line must begin. Where there is no need for a binding shoot, which is the case with many small designs such as Fig. 46, any beads of the first line which require to be drawn in succeeding lines may remain up until they are done with. The result of this will be that the flushed loops will not be of uniform length. This is not always a disadvantage, though often it may be, especially where large solid spaces are flushed.

The weaver must determine by experiment whether a design requires binding, although the designer should be able to decide the matter and show his intention on the ruled paper.

If only a portion of a design requires binding it can often be managed by a little ingenuity on the part of the artist. For instance, in Fig. 49 the solid tree is the only portion of the pattern which absolutely needs binding when it is woven on a small scale. The artist has provided for this and at the same time improved the composition by introducing the twill in opposing diagonals at intervals across the tree.

If, however, an all-over binder is needed as in the case in Plate VIII, the binding is effected by means of an extra shuttle carrying a very fine thread of weft and

PLATE VIII.



following every third shoot of the thick weft which forms the body of the cloth. Before the binding shoot is thrown the pattern warp must all be lowered even if the next line of the plan indicates that some of the headles should remain up.

49

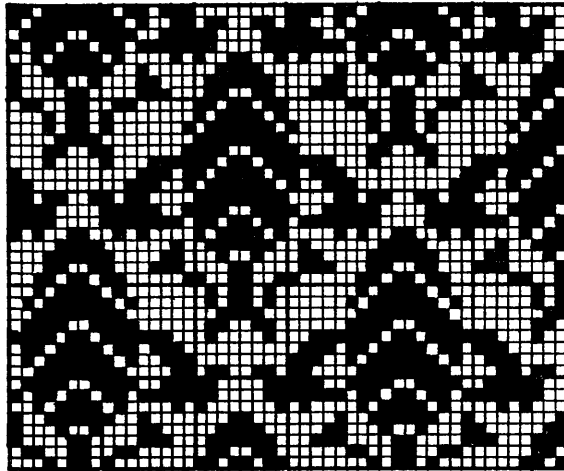

If in order to make the material reversible a back binder is also needed the pattern headles must all be raised and a second shoot of fine weft be thrown.

The above method of binding the design not only effects its purpose perfectly but solidifies the material woven and adds to the artistic appearance of the work.

Compound harness weaving is capable of immense development and diversity even on the small appliance, the table drawloom, but further explanation of it must be left for a future work on advanced weaving which the author hopes to produce ere long.

INDEX

- ALL-OVER binder, 68
Automatic pattern, 2
- BACK roller, 16
Batton, 8, 15
— swinging, 15
Bead, 14
Beaming, 9
— the warp, 17
Beating the weft, 14
Binding, 14
— shoot, 69
Brocading, 28
- CHECKERS, 58
Colour, 29
Compound harness weaving, 69
— pattern weaving, 60
Crossing twill, 49
- DAMASK weaving, 56
Diamond draught, 49
Dice patterns, 58
- EAST African native weaving, 30
Eight-headle harness, 6
Embellishments, 53
Entering, 9, 24
— the warp, 16
- FIGURED damasks, 40
Firmness of the web, 23
Floral shapes, 30
Flushing, 23
- GATING the loom, 25
Geometrical spots, 30
- HAND loom weaving, 2
— stick, 17
Handwork, 28
Harness holder, 4, 7
Headle table loom, 34
- IRISH poplin, 29
- JACQUARD weaving, 2
- LOOM harness, 13
—, parts of the, 2
- MAKING the warp, 16
Mill warping, 16
Mounting, 10
- ORDER of entering, 23
Ornamental weaving, 1, 31
— — pulley, 5
- PATTERN, automatic, 2
Plain entering, 35
— weaving, 28
Pulley mounting, 6
- RADDLE, 20
Reed, 8
— carrier, 15
— entering, 24
Regulating, 25
Reversed twills, 56
- SATINET texture, 47
Satins, 42
Serge texture, 40
Shedding motion, 4

Shuttle, 26
Side cords, 25
Silk taffeta, 29
Sleigh, 9
Slings, 21
Solid tree, 68
Sprigs, 31
Stringing, 10
Stripes, 29
Swinging batton, 15

TABBY ground, 28
— weaving, 28
Table drawloom, 69
— loom, 1
Tension, 21
Threading, 10

Tie up, 28
Treadle loom, 9
Trellis, 49
Tuned twills, 56
Turning the warp, 16
Tweed, 39
Twilling, 37

WARPING board, 16
— mill, 16
Warp, spreading the, 9
Weaving for Beginners, 2
—, Jacquard, 2
Weft beater, 8
Worsted tweed, 29
— weaving, 40

Pearsall's

WEAVING SILKS

for

WARP & WEFT

Organzines, Trams, Flosses,
Twists in
REAL & ARTIFICIAL
Silks in all sizes and
qualities.

Eastern Unfading, Boiling,
Washing & Ordinary Dyes.
Unwound or Wound
Gold, Silver and Oxidized
METAL THREADS.

*Weaving Specialities produced
and dyed to order in all qualities*

JAS. PEARSALL & CO., Ltd.
71/74 Little Britain, London, E.C.1

J. MAYGROVE & CO. LTD.

Manufacturers of every description of

YARNS FOR HAND LOOM WEAVING

PURE SILKS

Twists, Flosses, Sewings, Trams
and Organzines

COTTON YARNS

All counts and all qualities for
Warp and Weft

SPUN SILKS

Of every size and quality

WORSTED YARNS

All counts and all qualities for
all purposes

DYED YARNS HELD IN STOCK

*China Tram, Artificial Tram, Artificial Flosses—all sizes, Floche Silk, 2|30's
Worsted, 2|14's Worsted, 2|10's Worsted, 2|40's—2|12's Mercerised Cotton*

SPLENDID SELECTION of COLOURS in all the Principal Items

WAREHOUSE :

51/52 Aldersgate Street, London, E.C.1

Telephone: Clerkenwell 3824

Telegrams: Maygrove, Cent, London

MILLS: ST. ALBANS AND REDBOURN

BOOKS BY LUTHER HOOPER

HAND-LOOM WEAVING

In small crown 8vo, 368 pp., with 125 drawings by the AUTHOR and
NOEL ROOKE; coloured and half-tone reproductions. **10s. 6d.** net.

"Every phase and process in weaving is described with so clear and careful an exactitude that,
helped as the text is by the author's sketches and diagrams, the reader should have no difficulty
in conquering with its aid the rudiments of the craft."—*The Morning Post.*

"The book is itself a fine example of artistic work."—*The Glasgow Herald.*

"Mr. Luther Hooper is an expert on the subject, and his book will repay study by all interested
in the textile industries, and the resuscitation of the old crafts."—*The Nottingham Guardian.*

WEAVING FOR BEGINNERS

With plain directions for making a hand-loom, mounting it and starting the work

In foolscap 8vo, 144 pp., with 62 diagrams and illustrations. **5s.** net.

"This is a book on hand-loom weaving which differs from other works on weaving in the
respect that it deals with the actual construction of a hand-loom and supplies working drawings
of the woodwork for the carpenter, as well as dimensioned diagrams of the few metal parts that
are required. . . . the book will be very useful to anybody who desires to take up hand-loom
weaving."—*Glasgow Herald.*

"No better guide to hand-loom weaving can, we think, be found than in this book."—
Manchester City News.

LONDON: SIR ISAAC PITMAN & SONS, LTD., PARKER ST., KINGSWAY, W.C.2